

Synthesis of Input-rectifierless AC-DC Converters

J.C.P. Liu^{*†}, C.K. Tse^{*}, N.K. Poon^{*†}, Y.M. Lai^{*} and M.H. Pong[†]

^{*}Department of Electronic & Information Engineering, Hong Kong Polytechnic University, Hong Kong

[†]Department of Electrical and Electronic Engineering, University of Hong Kong, Hong Kong

Email: cpliu@eee.hku.hk & cktse@eic.polyu.edu.hk

Abstract — This paper discusses the basic construction procedure and topological possibilities of creating ac/dc converters out of simple dc/dc converters. It is shown that two separately controlled dc/dc converters are sufficient for producing a regulated dc output and shaping the input current, from an ac voltage source, without the need for input rectifiers. Some design constraints are discussed, emanating from the limitation of the conversion ratios that can be achieved by particular dc/dc converters. Selected topologies are verified experimentally.

Keywords — Ac/dc converter, dc/dc converter, rectifier, circuit topology, control.

I. INTRODUCTION

Ac/dc converters without input rectifiers have received some attention because of their relative advantages in eliminating power loss in rectifiers and reducing harmonic distortions. One straightforward approach to implement a rectifierless ac/dc converter is to construct two circuits (two complete converters), each working for either positive or negative half cycle of the line period. This approach, however, requires rather complicated circuits [1, 2]. Another possibility is to put the equivalent rectification in the secondary side where the diodes perform high-frequency as well as line-frequency rectification. This approach usually requires four quadrant switches and complicated topologies. Also, the high-current low-voltage condition in the secondary may present difficulty in raising the overall efficiency [3]. Recently, suitable converters having inherent ac/dc conversion capability have been studied by Ikriannikov and Čuk [4]. However, such converters, known as *bipolar-gain* converters [4], do not seem to have a systematic origin from which general synthesis procedure can be derived.

In this paper we consider the basic synthesis problem of a converter that converts an unrectified ac voltage to a dc voltage, without using an input rectifier. Our aim is to derive the simplest topology for ac/dc conversion, based on a combination of dc/dc converters.

II. DERIVATION OF THE SIMPLEST AC/DC CONVERTER

We begin with a black-box specification of ac/dc conversion. Let $u(t)$ be the output voltage, and $e(t)$ be the input voltage.

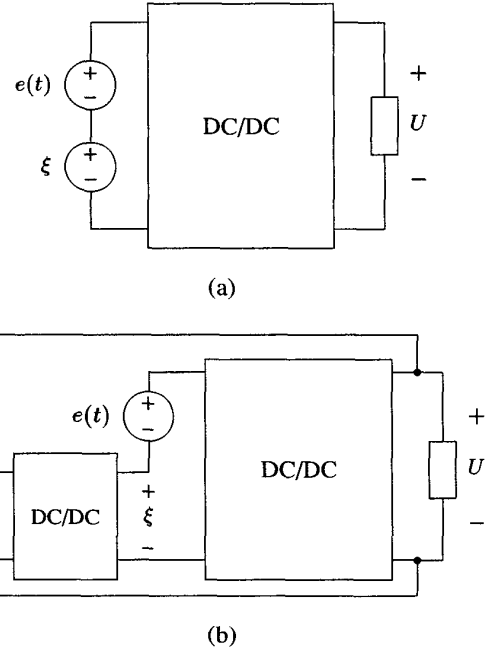

Fig. 1: Ac/dc conversion using (a) a dc/dc converter with a dc stack-up voltage; (b) two dc/dc converters

The ac/dc conversion specifies that

$$\begin{cases} u(t) = U & \text{where } U > 0 \\ e(t) = E \sin 2\pi f_e t & \text{where } E > 0 \end{cases} \quad (1)$$

In other words, we consider the usual conversion of a sinusoidal input voltage having a peak of E and frequency f_e into a fixed output voltage U . Our purpose is to derive the simplest input-rectifierless topology based on dc/dc converters that can fulfil the above black-box requirement.

A. Basic Construction

First of all, we observe that simple dc/dc converters only convert a dc voltage to another dc voltage. Thus, the use of a dc/dc converter for ac/dc conversion is handicapped mainly by its input side which cannot admit negative voltage values. The problem can be hypothetically solved if one stacks up a sufficiently large dc voltage over the ac input voltage before

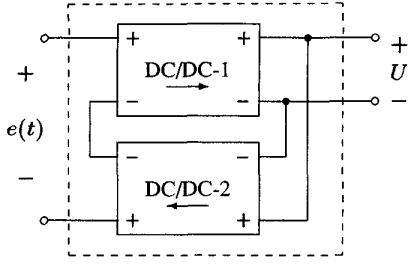

Fig. 2: Simplest input-rectifierless ac/dc converter

Condition	Converter 1	Converter 2
$E > U$	-	step-up
$E < U$	-	step-up/down
$U > \xi + E$	step-up	-
$U < \xi - E$	step-down	-
$\xi - E < U < \xi + E$	step-up/down	-

Table 1: Choice of converters

feeding into a dc/dc converter. This idea is illustrated in Fig. 1 (a), where ξ denotes the stack-up voltage. Obviously, we need

$$\xi > E. \quad (2)$$

Our next logical step is to create the required ξ . Clearly we need a second dc/dc converter which choicelessly must convert from the output voltage U . This gives the basic configuration shown in Fig. 1 (b), which is simply a series connection of two dc/dc converters. We may now construct our black-box ac/dc converter as shown in Fig. 2.

Remarks on isolation – It should be noted that when constructing the practical circuit, care should be taken to avoid short-circuit paths that may affect voltage conversion. One simple solution is to use isolated converters, though not always necessarily, to realize either converter 1 or converter 2. Moreover, if full isolation is required between $e(t)$ and U , then both converters should be isolated.

B. Constraints on Voltage Conversion Ratios

As shown in Fig. 2, converter 1 (labelled as DC/DC-1) must be capable of converting a variable dc voltage to a fixed dc voltage, whereas converter 2 (labelled as DC/DC-2) converts a fixed dc voltage to another fixed dc voltage. Suppose the voltage conversion ratios of converter 1 and converter 2 are k_1 and k_2 , respectively. We have

$$U = k_1 [e(t) + \xi] \quad (3)$$

$$\xi = k_2 U \quad (4)$$

Combining the above equations, the overall conversion ratio is given by

$$\frac{U}{e(t)} = \frac{k_1}{1 - k_1 k_2} \quad \text{for } e(t) \neq 0. \quad (5)$$

The case when $e(t) = 0$ corresponds to zero-crossing of the input waveform, i.e., $t = n/2f_e$ where $n = 0, 1, 2, \dots$. In this case, the input to converter 1 and the output from converter 2 are both equal to ξ , giving

$$k_1 = \frac{U}{\xi} \quad \text{and} \quad k_1 k_2 = 1, \quad \text{for } e(t) = 0. \quad (6)$$

To determine the constraints on the choice of dc/dc converters, we first observe that

$$k_2 > E/U \quad (7)$$

because $\xi > E$. Thus, if $E > U$, then converter 2 must be a step-up converter; otherwise, it can be an either step-up or step-down converter. Also, from (3), we can derive the the range of k_1 as

$$\frac{U}{\xi + E} < k_1 < \frac{U}{\xi - E} \quad (8)$$

Thus, if $U/(\xi + E) > 1$, converter 1 must be a step-up converter; if $U/(\xi - E) < 1$, converter 1 must be a step-down converter; and if $U/(\xi + E) < 1$ and $U/(\xi - E) > 1$, then converter 1 must be able to do both step-down and step-up at different time in a line cycle. Table 1 summarizes the choice of converters under different voltage conditions.

C. Power Flow Consideration

We now consider the way in which power is processed in the basic configuration shown in Fig. 2. First of all, assuming that the input current has the form

$$i_{in}(t) = \hat{i}_{in} \sin 2\pi f_e t, \quad (9)$$

the condition for power balance gives

$$\hat{i}_{in} = \frac{2P_o}{E} \quad (10)$$

where P_o is the output power. Thus, the power processed by converter 1 (labelled as DC/DC-1), $p_1(t)$, is

$$p_1(t) = (E \sin 2\pi f_e t + \xi) i_{in}(t) \quad (11)$$

and that by converter 2 (labelled as DC/DC-2), $p_2(t)$, is

$$p_2(t) = \xi i_{in}(t) \quad (12)$$

Integrating over a half mains cycle, we get the power processed by converter 1 during the positive mains cycle and the negative half mains cycle, respectively, as

$$\begin{aligned} P_1^+ &= 2f_e \int_0^{1/2f_e} (E \sin 2\pi f_e t + \xi) i_{in}(t) dt \\ &= P_o \left(1 + \frac{4\xi}{\pi E} \right) \end{aligned} \quad (13)$$

and

$$\begin{aligned} P_1^- &= 2f_e \int_{1/2f_e}^{1/f_e} (E \sin 2\pi f_e t + \xi) i_{in}(t) dt \\ &= -P_o \left(\frac{4\xi}{\pi E} \right) \end{aligned} \quad (14)$$

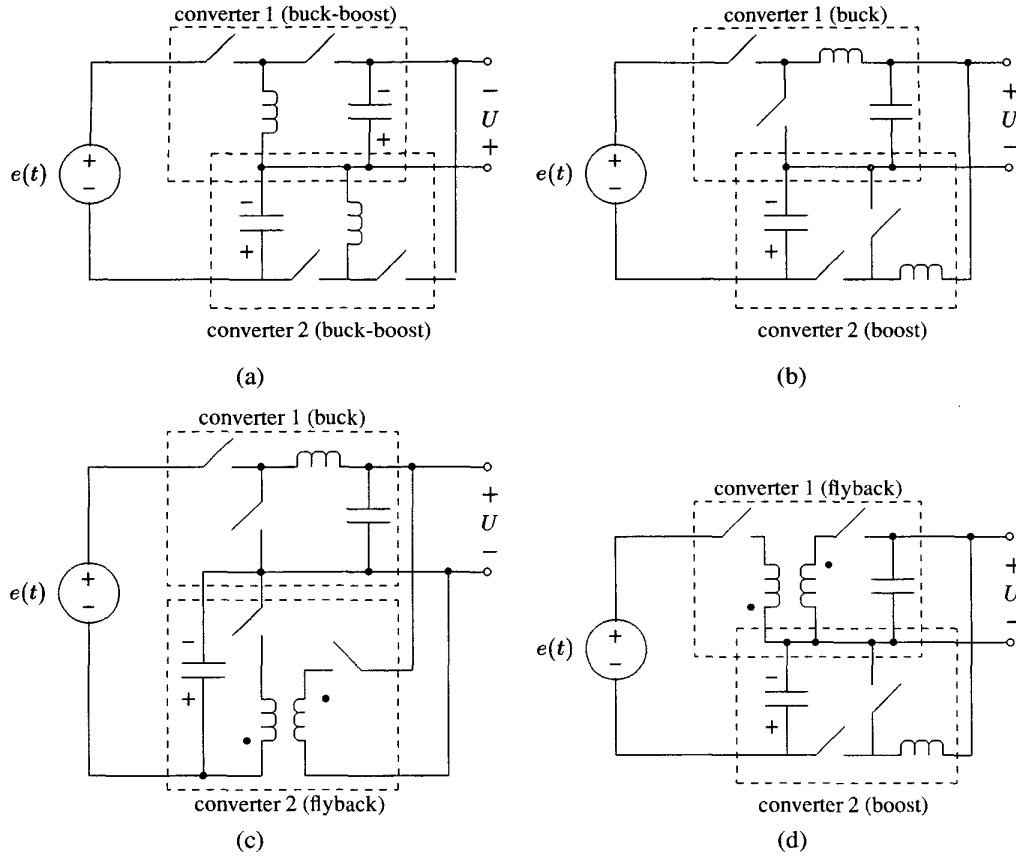

Fig. 3: Examples of simple input-rectifierless ac/dc converters. A flyback converter needed in (c) and (d) in lieu of buck-boost converter to reverse voltage polarity.

Likewise, we get the power processed by converter 2 during the positive mains cycle and the negative half mains cycle as

$$P_2^+ = -P_2^- = P_o \left(\frac{4\xi}{\pi E} \right) \quad (15)$$

Thus, we clearly see that the average power processed by converter 1 is P_o and that by converter 2 is zero, over one complete mains cycle. Both converters are required to be *bi-directional* since during the negative half mains cycle, power flow is essentially reversed. The overall effect is a circulation of power, which is equal to $(4\xi/\pi E)$, between the two converters. Such circulation may undesirably degrade the efficiency. Hence, to reduce this circulation, we may need to design the circuit with a lower ξ/E , meaning that the stack-up voltage ξ should be kept to minimum, as would be expected intuitively.

III. CIRCUIT IMPLEMENTATION OF SIMPLE AC/DC CONVERTERS

The implementation of an ac/dc converter based on the foregoing configuration can be proceeded by inserting appropriate dc/dc converters to the model. Fig. 3 (a) shows a non-isolated ac/dc converter which is constructed with a buck converter and a flyback converter serving as converters 1 and 2, respectively,

and Fig. 3 (b) shows another non-isolated ac/dc converter which is constructed with a buck converter and a boost converter serving as converters 1 and 2, respectively. Note that in Figs. 3 (c) and (d), the flyback converter achieves polarity reversal, and does not provide isolation for the entire ac/dc converter unless the other dc/dc converter is also isolated.

IV. EXTENSION OF BASIC TOPOLOGIES

The same idea can be implemented with higher-order dc/dc converters. For example, the Čuk converter has two possible dc outlets which can be used as input to converter 2, as described in Section II. Likewise, the zeta and SEPIC converters can serve the purpose. Fig. 4 shows the conceptual arrangement.

Suppose converter 1 (labelled as DC/DC-1 in Fig. 4) has an extra output voltage U' which can be used to feed converter 2 (labelled as DC/DC-2). Let k_{11} , k_{12} and k_2 be the voltage ratios defined as follows.

$$k_{11} = \frac{U}{e(t) + \xi} \quad (16)$$

$$k_{12} = \frac{U'}{e(t) + \xi} \quad (17)$$

$$k_2 = \frac{\xi}{U'} \quad (18)$$

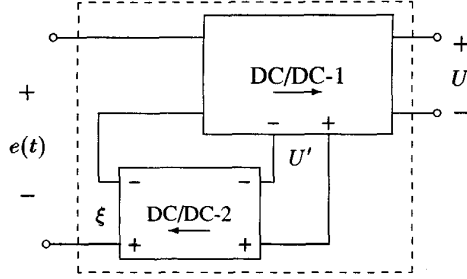

Fig. 4: Implementation of input-rectifierless ac/dc converter using higher-order dc/dc converters (DC/DC-1 can be Ćuk, SEPIC or zeta converter)

The constraints imposed on the voltage ratios can be derived in a similar manner as in Section II.. First of all, ξ must be larger than E , i.e.,

$$k_2 > E/U' \quad (19)$$

Moreover, k_{11} and k_{12} are not independent. For the Ćuk converter, for example, we have $1 + k_{11} = k_{12}$, which means

$$U' = U + e(t) + \xi \quad \text{with } \acute{C}\text{uk as converter 1.} \quad (20)$$

Obviously, we have $U' > U$, since $e(t) > -E$ for all time. Thus, (19) becomes

$$k_2 > E/U \quad \text{with } \acute{C}\text{uk as converter 1.} \quad (21)$$

So, if $E > U$, converter 2 should be a step-up converter; otherwise it can be either a step-up or step-down converter. As for converter 1, we observe that

$$\frac{U}{\xi + E} < k_{11} < \frac{U}{\xi - E} \quad (22)$$

Thus, if $U/(\xi + E) > 1$, converter 1 must be a step-up converter; if $U/(\xi - E) < 1$, converter 1 must be a step-down converter; and if $U/(\xi + E) < 1$ and $U/(\xi - E) > 1$, then converter 1 must be able to do both step-down and step-up at different time in a line cycle. If the Ćuk converter is used, the duty cycle can be controlled to satisfy these conditions.

V. CONTROL APPROACH

Suppose it is required that the input current be shaped to achieve unity power factor, in addition to a well regulated output voltage [5, 6, 7]. We may summarize the control requirements as follows:

- To produce a tightly regulated dc output voltage.
- To shape the input current to give unity power factor.
- To crudely control the level of the dc stack-up voltage.

It can be shown theoretically that two separate control parameters are needed to achieve the above requirements [8]. In our circuit, the allowable control parameters are the duty cycles of the two converters. Thus, in general, two control loops

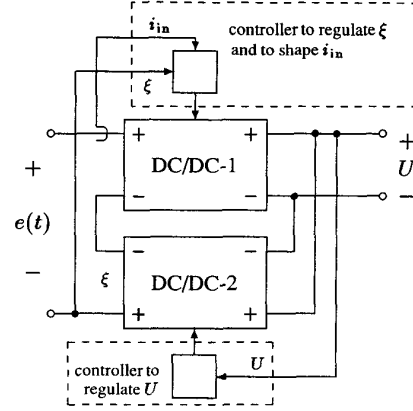

(a)

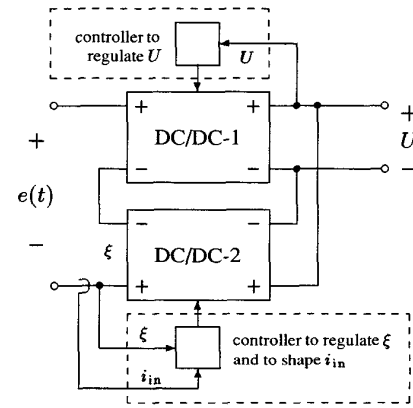

(b)

Fig. 5: Outline of two possible control approaches

should be designed, one for regulating the output voltage and the other for shaping the input current. Furthermore, since the converters are bi-directional, feedback can be assigned arbitrarily to the converters. Two cases are therefore possible:

- Converter 1 shapes the input current while converter 2 regulates the output voltage, as shown in Fig. 5 (a).
- Converter 1 regulates the output voltage while converter 2 shapes the input current, as shown in Fig. 5 (b).

The converter responsible for shaping the input current can also provide crude regulation for the stack-up voltage, as is usually done in practical power factor correction control.

VI. EXPERIMENTAL VERIFICATION

In this section, we report experimental results of a selected ac/dc converter that has been constructed using the afore-described synthesis process. The types of dc/dc converters used are same as the ones shown in Fig. 3 (d), i.e.,

- Converter 1 : flyback converter (turn ratio $n : 1$)
- Converter 2 : boost converter

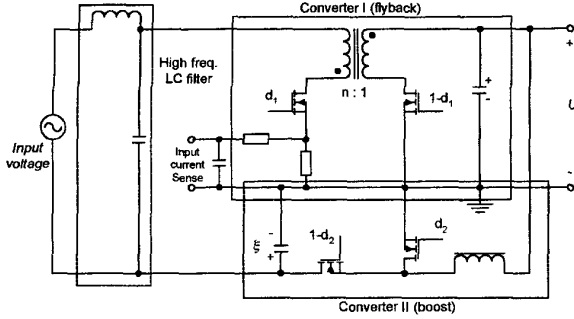

Fig. 6: Experimental converter circuit based on that of Fig. 3 (d)

Referring to Table 1, this particular choice of converter type is suitable for the cases where $E > U$ and ξ being any value. Moreover, efficiency consideration would suggest a low value for ξ .

The control consists of two separate feedback loops, as discussed in Section V. In particular, we employ the configuration shown in Fig. 5 (a), i.e., an input current shaper applied to the flyback converter and an output regulator applied to the boost converter. The input current shaper also regulates the stack-up voltage ξ . Figures 6 and 7 show the experimental converter and the schematic control circuit.

The test results are summarized in Table 2 for two different choices of ξ . The waveforms of the input voltage, input current, output voltage and stack-up voltage are shown in Fig. 8. It may be of interest to examine the conversion ratios of the individual converters for different input voltage levels, in order to verify the analytical equations developed in Section B. Let d_1 and d_2 be the duty cycle of converter 1 and converter 2, respectively. Then, k_1 and k_2 , as defined previously, are $k_1 = d_1/n(1-d_1)$ and $k_2 = 1/(1-d_2)$, respectively, where n is the flyback transformer turn ratio. Table 3 shows the values of duty cycles and voltage ratios for a few input voltage levels. Note that at the zero crossing of the input voltage, i.e., $e(t) = 0$, the product of the two conversion ratios is equal to one, as predicted in Section B. Finally, we observe that the efficiency of the converter drops significantly when the stack-up voltage is large, consistent with our earlier analysis of the power circulation problem.

VII. CONCLUSION

Most conventional ac/dc converters contain an input rectifier which provides a rectified full-wave input voltage for subsequent processing by one or more converters depending upon the functional requirements [9, 10]

In this paper we show that dc/dc converters can be used to construct ac/dc converters without the need for input rectifiers. The main purpose of this paper is to point out the basic construction procedure and topological possibilities of creating ac/dc converters out of simple dc/dc converters. In particular, it has been shown that

- two dc/dc converters are sufficient;

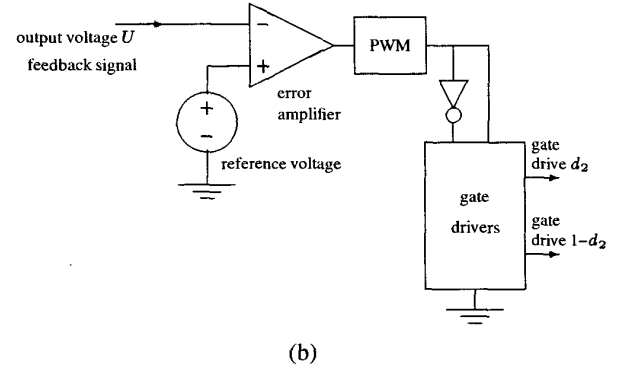
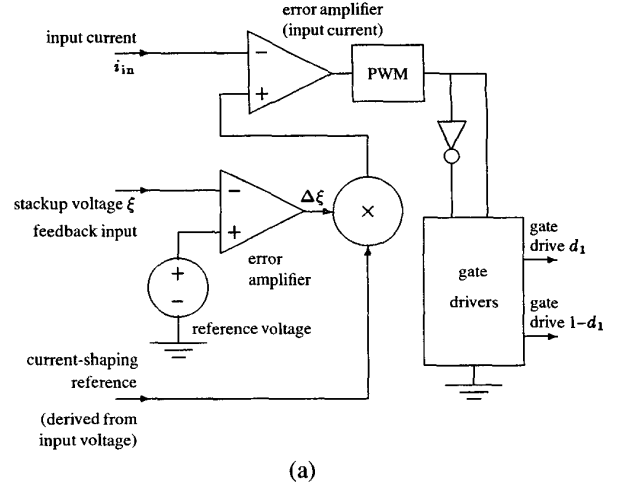
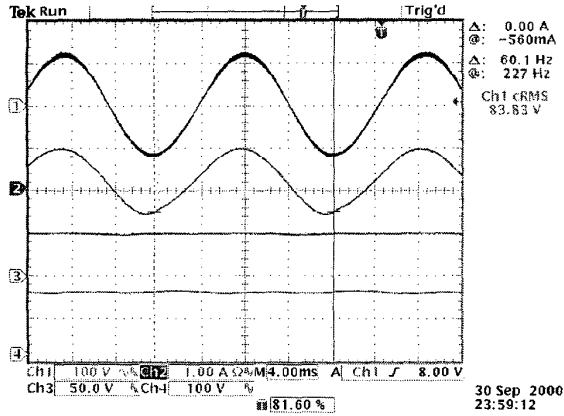

Fig. 7: Control circuit for (a) regulating ξ (crudely) and shaping input current; (b) regulating U (tightly).

- the two dc/dc converters should permit bi-directional power flow;
- the two dc/dc converters should be separately controlled to achieve output regulation and input current shaping;
- some power is being circulated between the two converters.

Furthermore, some design constraints have been discussed, emanating from the limitation of the conversion ratios that can be achieved by particular types of converters. The idea has been experimentally tested with a prototype circuit.

While the present work focuses on the basic synthesis problem, the efficiency issue may be a practical concern. Essentially, since circulating power always exists, loss becomes inevitable and can be quite large if the stack-up dc voltage is not properly controlled. Note that the loss is proportional to the ratio of the stack-up voltage to the peak input voltage. Thus, as a simple rule, the stack-up voltage should be just above the peak input voltage in order to maintain proper operation. Moreover, a special variable stack-up voltage control may be explored for minimizing circulation loss. This will be a future research topic.



(a) Test 1

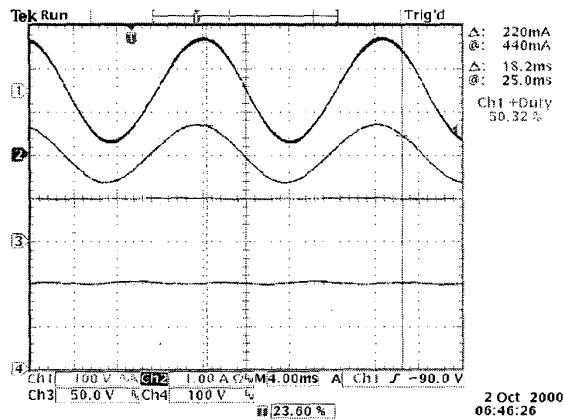

(b) Test 2

Fig. 8: Waveforms of input voltage, input current, output voltage and stack-up voltage for (a) stack-up voltage = 140 V; and (b) stack-up voltage = 204 V. Trace 1: input voltage (100V/div), Trace 2: input current (1A/div), Trace 3: output voltage (50V/div), Trace 4: stack-up voltage ξ (100V/div)

REFERENCES

- [1] I. Kim and B.K. Bose, "A new ZCS turn-on and ZVS turn-off unity power factor PWM rectifier with reduced conduction loss and no auxiliary switches," *IEEE PESC Rec.*, pp. 1344-1350, 1998.
- [2] E. Rodriguez, O. Garcia, J.A. Cobos, J. Arau and J. Uceda, "A single-stage rectifier with PFC and fast regulation of the output voltage," *IEEE PESC Rec.*, pp. 1642-1648, 1998.
- [3] A. Sulistyono and P.N. Enjeti, "A series resonant ac-to-dc rectifier with high-frequency isolation," *Proc. IEEE APEC*, pp. 379-402, 1994.
- [4] A. Ikriannikov and S. Čuk, "Direct ac/dc conversion without input rectification," *IEEE PESC Rec.*, pp. 181-186, 1999.

Parameters	Test 1	Test 2
Input voltage E	121 V (peak)	121 V (peak)
Input current i_{in}	0.735 A (peak)	0.637 A (peak)
Output voltage U	48 V	48 V
Output current	0.7 A	0.5 A
Flyback turn-ratio	1:1	3:1
Stack-up voltage ξ	140.83 V	199.41 V
Power input P_{in}	44.5 W	38.5 W
Power output P_o	33.6 W	24 W
Efficiency	75.9 %	62.3 % (consistent with higher ξ)

Table 2: Experimental measurements for an input-rectifierless ac/dc converter using a flyback converter and a boost converter

	input = -98V		input = 0V		input = +86V	
	Test 1	Test 2	Test 1	Test 2	Test 1	Test 2
U	48 V	48 V	48 V	48 V	48 V	48 V
ξ	142 V	204 V	140 V	202 V	139 V	198 V
d_1	0.515	0.575	0.263	0.424	0.190	0.349
d_2	0.657	0.757	0.657	0.757	0.653	0.757
k_1	1.062	0.451	0.345	0.245	0.235	0.179
k_2	2.915	4.115	2.915	4.115	2.881	4.115
$k_1 k_2$	3.096	1.856	1.04	1.008	0.677	0.737

Table 3: Measured duty cycles and voltage ratios for different input voltage levels for an input-rectifierless ac/dc converter using a flyback converter and a boost converter

- [5] C. Zhou and M. Jovanović, "Design trade-offs in continuous current-mode controlled boost power-factor correction circuits," *High Freq. Power Conv. Conf.*, pp. 209-220, 1992.
- [6] R. Redl, "Power-factor correction in single-phase switching-mode power supplies," *Int. J. Electronics*, Vol. 77, No. 5, pp. 555-582, 1994.
- [7] Ch. Andrieu, J.P. Ferrieux and M. Rocher, "The ac/dc stage: a survey of structures and chopper control modes for power factor correction," *EPE Journal*, Vol. 5, No. 3/4, pp. 17-22, Jan 1996.
- [8] C.K. Tse and M.H.L. Chow, "Theoretical study of switching converters with power factor correction and output regulation," *IEEE Trans. Circ. & Syst. I*, Vol. 47, No. 7, pp. 1047-55, July 2000.
- [9] R. Erickson, M. Madigan and S. Singer, "Design of simple high power factor rectifier based on the flyback converter," *Proc. IEEE APEC*, 1990.
- [10] L. Dixon, "High power factor preregulator for offline power supply," *Unitrode Switching Regulated Power Supply Design Seminar Manual*, pp. 12.1-12, 1990.