

Performance of Asynchronous Orthogonal Multicarrier CDMA System in Frequency Selective Fading Channel

Xiang Gui, *Member, IEEE*, and Tung Sang Ng, *Senior Member, IEEE*

Abstract—An asynchronous multicarrier (MC) direct-sequence (DS) code-division multiple-access (CDMA) scheme for the uplink of the mobile communication system operating in a frequency selective fading channel is analyzed. Bit error rate performance of the system with either equal-gain combining or maximum-ratio combining is obtained. Numerical results indicate that the system performs better than that of the conventional DS-CDMA system and another MC-DS-CDMA system.

Index Terms—Code division multiple access, direct sequence, frequency selective fading, orthogonal multicarrier, spread spectrum.

I. INTRODUCTION

FREQUENCY selective multipath fading is common in urban and indoor environments and is a significant source of potential degradation in a wideband mobile communication system. A direct-sequence spread-spectrum (DS-SS) code-division multiple-access (CDMA) scheme used for high-data-rate applications is usually known as broadband CDMA (B-CDMA) [1] due to its large bandwidth. Multipath propagation causes interchip-interference (ICI) in the DS-SS-CDMA system and severe intersymbol-interference in high data rate systems if the channel delay spread exceeds the symbol duration [2], [3]. As pointed out in [2], the use of conventional CDMA does not seem to be realistic when the data transmission rate goes to the order of a hundred megabits per second due to the severe ICI and the difficulty to synchronize such a fast sequence. Techniques of reducing both the symbol rate and chip rate are essential in this case.

Orthogonal multicarrier modulation [5]–[9] combined with CDMA has been proposed to solve the problem. Such a system is usually referred to as multicarrier CDMA or orthogonal frequency-division multiplexing CDMA (OFDM-CDMA) and has drawn a lot of interest in wireless personal multimedia communications in recent years. Various multicarrier CDMA schemes have been proposed in the literature [2]–[4], [10]–[14]. The common point of these proposals is

to change the conventional serial transmission of data/chip stream into parallel transmission of data/chip symbols over a large number of narrow band orthogonal carriers, hence the bit and chip duration is increased proportionally. An interesting aspect of the multicarrier CDMA is that its modulation and demodulation can be implemented easily by means of IDFT and DFT operators [7]–[9].

As discussed in [15], the multicarrier CDMA schemes can be categorized into two groups: One spreads the original data stream using a given spreading code, and then modulates different carriers with each chip, i.e., spreading in the frequency domain. The other group spreads the serial-to-parallel converted data streams using a given spreading code and then modulates different carriers with each data stream, i.e., spreading in the time domain similar to a conventional DS-CDMA scheme. There are two schemes in the second category, and the difference between them is on the subcarrier frequency separation. If we denote the chip duration and bit duration with T_s and T_b , respectively, then the subcarrier separation in one system is $1/T_s$, and in the other system is $1/T_b$. The former is given the name multicarrier DS-CDMA (MC-DS-CDMA), and the later is called multitone CDMA (MT-CDMA). Performance of both schemes has been analyzed in the asynchronous uplink channel [3], [16]. There is only one scheme in the first category, and it is generally referred to as MC-CDMA. Its performance has been studied for the downlink of a mobile communication system [10] in which perfect time synchronization among users is assumed. In addition, it is also assumed that the fading of the subcarriers is independent of each other. Nevertheless, these two assumptions are not guaranteed in practice. Perfect time synchronization is difficult to achieve in the uplink of a mobile communication system, and the fading of the subcarriers is usually correlated due to insufficient frequency separation between the subcarriers.

In this paper, we analyze the *asynchronous* MC-CDMA system with *correlated* fading among subcarriers. The rest of the paper is organized as follows: the asynchronous MC-CDMA system model is described in Section II. Its performance is analyzed in Section III. Numerical results are presented and discussed in Section IV. Finally, Section V gives the conclusion.

II. ASYNCHRONOUS MC-CDMA SYSTEM MODEL

The MC-CDMA system described in [15] transmits L chips of a data symbol in parallel on L different carriers, one chip

Paper approved by R. Kohno, the Editor for Spread Spectrum Theory and Applications for the IEEE Communications Society. Manuscript received March 5, 1998; revised August 24, 1998. This work was supported by the Hong Kong Research Grants Council and the CRCG of the University of Hong Kong.

X. Gui is with the School of Electrical and Electronic Engineering, Nanyang Technological University, Singapore 639798 (e-mail: exgui@ntu.edu.sg).

T. S. Ng is with the Department of Electrical and Electronic Engineering, the University of Hong Kong, Hong Kong (e-mail: tsng@eee.hku.hk).

Publisher Item Identifier S 0090-6778(99)05235-6.

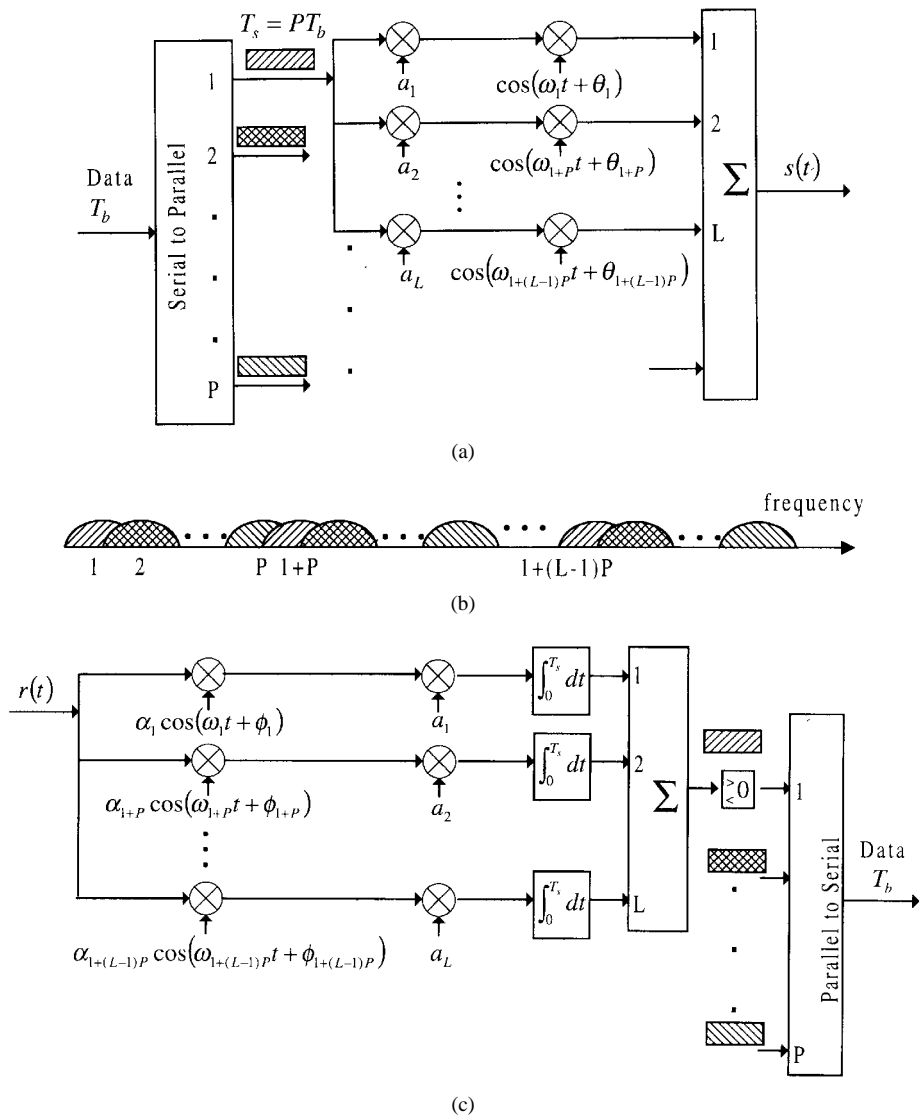

Fig. 1. (a) MC-CDMA transmitter. (b) Spectrum of the transmitted signal (chips of the same data bit with the same pattern). (c) MC-CDMA receiver.

per carrier, where L is the total number of chips per data bit or processing gain (PG). Thus, the chip duration T_s of the MC-CDMA system is the same as the bit duration T_b . We assume the use of random spreading sequence throughout this paper. The frequency separation between the neighboring carriers is $1/T_s$ Hz. Hence, the carriers are orthogonal on chip duration T_s . It is crucial for multicarrier transmission to have frequency nonselective fading over each carrier [15]. Therefore, serial-to-parallel conversion of the original data stream may be needed to increase the chip duration to avoid frequency selective fading. Hence, a generalized MC-CDMA system may transmit PL chips of P data bits on PL carriers, one chip per carrier. The frequencies of the orthogonal carriers is related by

$$f_i = f_1 + (i-1) \frac{1}{T_s}, \quad i = 1, 2, \dots, PL. \quad (1)$$

Clearly, the power spectrum of signals transmitted on successive carriers overlaps. In order to achieve frequency diversity, the assignment of PL carriers to the PL chips is made such that the frequency separation among carriers conveying the chips of the same data bit is maximized. Hence the L chips of

a data in p th data stream ($p = 1, 2, \dots, P$) is transmitted on the L carriers with frequencies $\{f_{p+(l-1)P}, l = 1, 2, \dots, L\}$, and the adjacent frequency separation between these carriers is P/T_s . The block diagram of such a MC-CDMA system is depicted in Fig. 1. To make the system performance under different configurations comparable, we fix the pass-band null-to-null bandwidth and the data transmission rate of the system. Let us start with a conventional DS-SS-CDMA system, if it has a chip duration T_c and bit duration T_b , then its PG is $L_1 = T_b/T_c$, the pass-band null-to-null bandwidth is $2/T_c$ assuming rectangular waveform, and the data rate is $1/T_b$. For a MC-CDMA system with PL subcarriers, its bandwidth is given by $(PL+1)(1/T_s)$, and its data rate is P/T_s . Hence, we have

$$(PL+1) \frac{1}{T_s} = \frac{2}{T_c} \quad (2)$$

and

$$\frac{P}{T_s} = \frac{1}{T_b}. \quad (3)$$

From (2) and (3) we find

$$T_s = PT_b \quad (4)$$

and

$$L = \frac{2PL_1 - 1}{P}. \quad (5)$$

We can see the chip duration of the MC-CDMA system is PL_1 times as long as that of a DS-CDMA system, and the PG of the MC-CDMA is nearly twice as high as that of DS-CDMA, which reflects the 50% spectral overlapping in the MC-CDMA system. However, if pulse shaping filters such as raised cosine filters are used in the DS-CDMA system, the bandwidth of DS-CDMA is approximately $1/T_c$ when the roll-off factor α of the raised cosine filter is small. Under this situation, (2) is changed to

$$(PL + 1) \frac{1}{T_c} = \frac{1}{T_c}. \quad (6)$$

From (6) and (4) we obtain

$$L = \frac{PL_1 - 1}{P}. \quad (7)$$

Hence, the PG of the MC-CDMA is nearly the same as that of DS-CDMA when a pulse shaping filter is included. Of course, the use of pulse shaping filters in DS-CDMA degrade the system performance and introduce other difficulties to the RAKE receiver [15], [23].

On the one hand, to have frequency nonselective fading on each carrier, the following condition must be satisfied:

$$1/T_c \ll (\Delta f)_c \quad (8)$$

where $(\Delta f)_c$ is the coherence bandwidth of the channel [17]. The reciprocal of $(\Delta f)_c$ is a measure of the multipath spread of the channel and is denoted by T_m , i.e., $T_m \approx 1/(\Delta f)_c$. On the other hand, to have independent fading among carriers carrying chips of the same data bit, the following condition must be satisfied:

$$(\Delta f)_c \ll P/T_s. \quad (9)$$

Furthermore, to have a near constant fading characteristic during a chip duration in a time-selective channel, the following condition must be satisfied:

$$T_s \ll (\Delta t)_c \quad (10)$$

where $(\Delta t)_c$ is the coherence time of the channel [17]. Usually the conditions (8)–(10) cannot all be satisfied. For condition (8), the larger P is better, but for condition (10), P can not be too large. We assume $T_m = NT_c$, where N is an integer and the DS-CDMA system has multipath fading in the channel. Normally the number of multipaths $N \ll L_1$. Note that the inequality (9) actually requires $1/N \ll 1/L_1$. Hence, condition (9) is usually not fulfilled, and fading among subcarriers assigned to the same data bit is correlated. On the other hand, conditions (8) and (10) are easily satisfied by proper choice of P due to the fact that $(\Delta t)_c$ is usually much larger than T_m . Hence, we assume that each carrier of the MC-CDMA system is subject to frequency nonselective fading, while the fading characteristic is constant over at least one chip

interval and the fading of carriers is correlated. Furthermore, although not necessary, we assume the fading characteristic is identical for each carrier to simplify the problem. Specifically, the complex low-pass impulse response of the channel for carrier i of user k is assumed to be

$$g_{k,i}(t) = \beta_{k,i}(t) e^{j\varphi_{k,i}(t)} \quad (11)$$

which is a complex Gaussian random variable (r.v.) with zero mean and variance σ^2 . The path gains $\{\beta_{k,i}(t)\}$ are i.i.d. for different k , and identical but correlated for different i and t and for the same k . Thus we have

$$E[g_{k,i}^*(t)g_{k,i+\lambda}(t+\tau)] = \sigma^2 \rho(\lambda/T_s) \gamma(\tau) \quad (12)$$

where $\rho(\cdot)$ and $\gamma(\cdot)$ are a normalized frequency correlation function and time correlation function with $\rho(0) = 1$ and $\gamma(0) = 1$, respectively. Equation (12) implies that we are assuming the multipath dispersion and the Doppler variation as two independent events [18], [19]. The function $\rho(\cdot)$ is also called spaced-frequency correlation function of the channel and it can be obtained by taking the Fourier transform of the multipath intensity profile $\phi_c(\tau)$ [17]. Hence, given the multipath intensity profile $\phi_c(\tau)$ of the channel, $\rho(\cdot)$ is determined. Since the bandwidth of the signal sent on each carrier is very narrow compared to the channel coherent bandwidth, we assume that the fading characteristic of the signal is the same as that of its carrier.

III. PERFORMANCE ANALYSIS

According to the block diagram of the MC-CDMA transmitter shown in Fig. 1(a), the transmitted BPSK signal of user k can be written as

$$s_k(t) = \sum_{n=-\infty}^{+\infty} \sqrt{2S_k} \sum_{p=1}^P \sum_{l=1}^L b_{k,p}(n) a_{k,l}(n) u_{T_s}(t - nT_s) \cdot \cos(\omega_i t + \theta_{k,i}) \quad (13)$$

where $u_{T_s}(t)$ is the rectangular waveform defined as

$$u_{T_s}(t) = \begin{cases} 1, & 0 \leq t \leq T_s \\ 0, & \text{elsewhere} \end{cases} \quad (14)$$

and the subscript

$$i = p + (l - 1)P. \quad (15)$$

The transmission power on different carriers is the same and is denoted by S_k , $b_{k,p}(n)$ is the n th data bit in the p th data stream of user k , $a_{k,l}(n)$ is the l th chip of the n th data bit in the data stream of user k , and ω_i is the i th carrier frequency given by $\omega_i = 2\pi f_i$ where f_i is given in (1). The random phase $\theta_{k,i}$ of i th carrier of user k is uniformly distributed over $[0, 2\pi)$ and is independently identically distributed (i.i.d.) for different k and i . From (13), we can see that there are P data streams for user k . The data bits on all the streams are aligned in time and indexed by n , with each data bit having the rectangular waveform of duration T_s as defined by $u_{T_s}(t)$. Each data bit has L spreading chips and is denoted by $a_{k,l}(n)$. Note that data bits on different streams with the same time index use the same spreading sequence. The L chips of a data bit are sent in

parallel on L carriers indexed by i , where i is determined by l as given in (15). That is, the neighboring carriers of a data bit are separated by $P - 1$ carriers of other data bits in order to achieve maximum frequency diversity.

Assuming K asynchronous CDMA users in the system, all using the same selection of P and L , the power received from each user at the base station is the same under no fading conditions. The received signal at the base station is given by

$$r(t) = \eta(t) + \sum_{n=-\infty}^{+\infty} \sqrt{2S} \sum_{k=1}^K \sum_{p=1}^P \sum_{l=1}^L \beta_{k,i}(t) b_{k,p}(n) a_{k,l}(n) \cdot u_{T_s}(t - nT_s - \zeta_k) \cos(\omega_i t + \phi_{k,i}(t)) \quad (16)$$

where S denotes the received signal power at the base station, $\phi_{k,i}(t) = \theta_{k,i} + \varphi_{k,i}(t) - \omega_i \zeta_k$, ζ_k is the time misalignment of user k with respect to the reference user at the receiver which is i.i.d. for different k and uniformly distributed in $[0, T_s]$, and $\eta(t)$ is the additive white Gaussian noise with zero mean and unilateral power spectral density N_0 . As shown in (16), the i th carrier of user k is subject to frequency nonselective Rayleigh fading with amplitude attenuation $\beta_{k,i}(t)$ and phase shift $\varphi_{k,i}(t)$. With coherent reception and user 1 as the reference user whose ζ_1 is zero, the decision variable U_p of the 0th data bit of the p th data stream of user 1 is given by

$$U_p = \int_0^{T_s} r(t) \sum_{l=1}^L a_{1,l}(0) \cos(\omega_l t + \phi_{1,i}(0)) \alpha_{1,i} dt. \quad (17)$$

Due to slow fading, the path gain and phase shift variables are considered to be constant over the time interval $[0, T_s]$ and is denoted by $\beta_{1,i}(0)$ and $\varphi_{1,i}(0)$, respectively. Depending on the choice of $\{\alpha_{1,i}\}$, there are two ways of combining the chips of the same data bit: equal gain combining (EGC) and maximum ratio combining (MRC) [20]. Both will be studied in the following.

A. Equal Gain Combining

With EGC, $\alpha_{1,i} = 1$ for all i . As shown in the Appendix, (17) can be rewritten as

$$U_p = D_p + \eta + I + J_p. \quad (18)$$

The term D_p is the desired output

$$D_p = \sqrt{\frac{S}{2}} T_s b_{1,p}(0) \sum_{l=1}^L \beta_{1,i}(0) \quad (19)$$

where i is given in (15) and η is the interference term due to Gaussian noise with zero mean and variance $N_0 L T_s / 4$. In (18), the term I is the same carrier interference from other users given by

$$I = \sqrt{\frac{S}{2}} \sum_{k=2}^K \sum_{l=1}^L \beta_{k,i}(0) \cos(\phi_{k,i}(0) - \phi_{1,i}(0)) \cdot \left[b_{k,p}(-1) a_{k,l}(-1) a_{1,l}(0) \zeta_k + b_{k,p}(0) \cdot a_{k,l}(0) a_{1,l}(0) (T_s - \zeta_k) \right]. \quad (20)$$

J_p is other carrier interference from other users given by

$$J_p = \sqrt{\frac{S}{2}} \sum_{k=2}^K \sum_{l=1}^L \sum_{q=1}^P \sum_{\substack{h=1 \\ j \neq i}}^L \beta_{k,j}(0) \cdot \left\{ \int_0^{\zeta_k} b_{k,q}(-1) a_{k,h}(-1) a_{1,l}(0) \cos((\omega_i - \omega_j)t + \phi_{k,j}(0) - \phi_{1,i}(0)) dt + \int_{\zeta_k}^{T_s} b_{k,q}(0) a_{k,h}(0) \cdot a_{1,l}(0) \cos((\omega_i - \omega_j)t + \phi_{k,j}(0) - \phi_{1,i}(0)) dt \right\} \quad (21)$$

where $j = q + (h - 1)P$. Due to the assumption that $\theta_{k,i}$ is i.i.d. for different k and i , it is easy to show that all terms in the summation of (20) and (21) are uncorrelated, and I and J_p are uncorrelated. Hence, both I and J_p are approximately Gaussian. By averaging (20) and (21) over $\beta_{k,i}$, $\theta_{k,i}$, and ζ_k , we find that both I and J_p have zero mean and variance

$$\text{var}(I) = (K - 1) L S \sigma^2 T_s^2 / 3 \quad (22)$$

$$\text{var}(J_p) = \frac{(K - 1) S \sigma^2 T_s^2}{4\pi^2} \sum_{l=1}^L \sum_{\substack{j=1 \\ i \neq j}}^{PL} \frac{1}{(i - j)^2} \quad (23)$$

respectively. From (18), (19), (22), and (23), assuming a "one" is transmitted, the mean and variance of U_p are given, respectively, by

$$E(U_p) = \sqrt{\frac{S}{2}} T_s \sum_{l=1}^L \beta_{1,i}(0) \quad (24)$$

and

$$\text{var}(U_p) = N_0 L T_s / 4 + (K - 1) S \sigma^2 T_s^2 (L/3 + Q_p / 4\pi^2) \quad (25)$$

where

$$Q_p = \sum_{l=1}^L \sum_{\substack{j=1 \\ i \neq j}}^{PL} \frac{1}{(i - j)^2}. \quad (26)$$

We see U_p is conditional Gaussian conditioned on $\{\beta_{1,i}(0)\}$. The r.v. set $\{\beta_{1,i}(0)\}$ in (24) consists of L correlated Rayleigh random variables. Since the fading for each carrier is assumed identical, $\{\beta_{1,i}(0)\}$ is identical for different p . Furthermore, $\{\beta_{1,i}(0)\}$ is also identical for different data bit and the choice of the 0th data bit as the reference data bit is in fact arbitrary. Hence, for simplicity, we use $\{\beta_l, l = 1, 2, \dots, L\}$ to denote $\{\beta_{1,i}(0)\}$ in what follows. Hence, the probability of error conditioned on $\{\beta_l\}$ is simply given by

$$P[e|\{\beta_l\}] = \frac{1}{2} \text{erfc} \left(\frac{E(U_p)}{\sqrt{2 \text{var}(U_p)}} \right). \quad (27)$$

Then the bit error rate (BER) for the p th data stream is obtained via averaging $P[e|\{\beta_l\}]$ over $\{\beta_l\}$

$$\text{BER}_p = \int_0^\infty P[e|\{\beta_l\}] p(\beta_1, \beta_2, \dots, \beta_L) d\beta_1 d\beta_2 \dots d\beta_L \quad (28)$$

where $p(\beta_1, \beta_2, \dots, \beta_L)$ is the joint probability density function of $\{\beta_l\}$. It is assumed that any bit can be sent via any of the P data streams with equal probability. Therefore, the system average BER is given by

$$\text{BER} = \frac{1}{P} \sum_{p=1}^P \text{BER}_p. \quad (29)$$

The average signal-to-noise ratio (SNR) is defined by [3]

$$\text{SNR} = \frac{ST_s}{N_0L} E \left[\left(\sum_{l=1}^L \beta_l \right)^2 \right]. \quad (30)$$

The evaluation of (28) and $E[(\sum_{l=1}^L \beta_l)^2]$ in (30) can be done by Monte Carlo integration [3], [22].

B. Maximum Ratio Combining

For the use of MRC, the channel gain of each carrier must be continuously estimated, which may not be feasible in practice. However, the study gives a lower bound of the system BER. With MRC, $\alpha_{1,i} = \beta_l$. Equation (17) can be rewritten in the form of (18) as well (see Appendix), with the variance of η change to $(N_0T_s/4) \sum_{l=1}^L \beta_l^2$, and (19)–(21) become

$$D_p = \sqrt{\frac{S}{2}} T_s b_{1,p}(0) \sum_{l=1}^L \beta_l^2 \quad (31)$$

$$I = \sqrt{\frac{S}{2}} \sum_{k=2}^K \sum_{l=1}^L \beta_l \beta_{k,i}(0) \cos(\phi_{k,i}(0) - \phi_{1,i}(0)) \cdot [b_{k,p}(-1)a_{k,l}(-1)a_{1,l}(0)\zeta_k + b_{k,p}(0)a_{k,l}(0) \cdot a_{1,l}(0)(T_s - \zeta_k)] \quad (32)$$

and

$$J_p = \sqrt{\frac{S}{2}} \sum_{k=2}^K \sum_{l=1}^L \sum_{q=1}^P \sum_{\substack{h=1 \\ j \neq i}}^L \beta_l \beta_{k,j}(0) \cdot \left\{ \int_0^{\zeta_k} b_{k,q}(-1)a_{k,h}(-1)a_{1,l}(0) \cdot \cos((\omega_i - \omega_j)t + \phi_{k,j}(0) - \phi_{1,i}(0)) dt \right. \\ \left. + \int_{\zeta_k}^{T_s} b_{k,q}(0)a_{k,h}(0)a_{1,l}(0) \cdot \cos((\omega_i - \omega_j)t + \phi_{k,j}(0) - \phi_{1,i}(0)) dt \right\}. \quad (33)$$

The interference terms I and J_p from other users are still approximately Gaussian with zero mean and variance

$$\text{var}(I) = \frac{(K-1)S\sigma^2T_s^2}{3} \sum_{l=1}^L \beta_l^2 \quad (34)$$

and

$$\text{var}(J_p) = \frac{(K-1)S\sigma^2T_s^2}{4\pi^2} \sum_{l=1}^L \beta_l^2 \sum_{\substack{j=1 \\ i \neq j}}^{PL} \frac{1}{(i-j)^2} \quad (35)$$

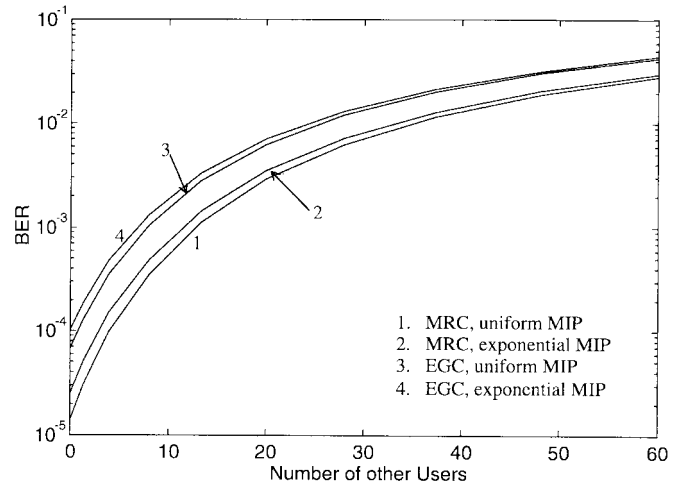

Fig. 2. Performance of asynchronous MC-CDMA using EGC or MRC ($P = 1$ and $\text{SNR} = 10$ dB).

respectively. Using (27)–(29), we can obtain the system BER with MRC, with $E(U_p)$ equals D_p given in (31), $\text{Var}(U_p)$ equals the sum of $\text{var}(I)$ and $\text{var}(J_p)$ given by (34) and (35), and the variance of η .

IV. NUMERICAL RESULTS

In order to compare the performance of asynchronous reception for MC-CDMA, MC-DS-CDMA studied in [3], and the conventional DS-CDMA, the fading channel parameters and the system data rate are fixed, and the bandwidth of these systems is approximately the same. The processing gain L_1 of the DS-CDMA system is fixed at 60. The channel is a multipath channel modeled as a finite tapped delay line with $N = 4$ Rayleigh fading paths and the multipath intensity profile (MIP) of the channel can be uniform or exponential, which is the same as that used in [3]. First we present some results for MC-CDMA. Setting $P = 1$, from (4) we obtain $T_s = 60T_c$. Since there are four paths in DS-CDMA, $T_m = 4T_c$. Therefore, condition (8) is fulfilled and each carrier in MC-CDMA has frequency nonselective fading, i.e., there are no multipaths at each carrier. However, condition (9) is obviously not satisfied, and the fading of carriers are correlated. The frequency correlation function $\rho(\cdot)$ can be obtained by taking the Fourier transform of the exponential multipath intensity profile as discussed in Section II. Hence, for MC-CDMA, the fading experienced by the chips of the same data bit is highly correlated. Using Monte Carlo integration, we can generate a correlated complex Gaussian random sequence [18], [21], [25] corresponding to $\rho(\cdot)$. The Rayleigh r.v. set $\{\beta_l\}$ can then be readily obtained based on the generated complex Gaussian random sequence. In the evaluation of the BER performance of MC-CDMA, $\{\beta_l\}$ is generated 100 000 times.

In Fig. 2, the BER's of asynchronous MC-CDMA with $P = 1$ using EGC and MRC are plotted against the number of other users, where the SNR is fixed at 10 dB. Both the uniform MIP and the exponential MIP are considered, and the PG $L = 119$, which is obtained from (5). The results are obtained by Monte Carlo integration. Here we mention that the

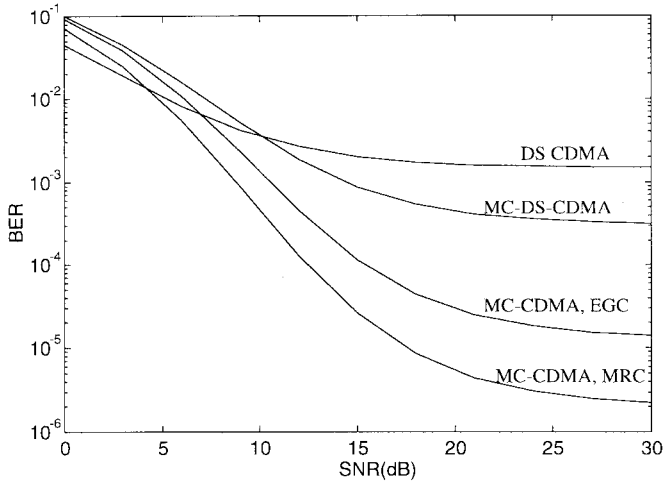

Fig. 3. Performance comparison among MC-CDMA, MC-DS-CDMA, and DS-CDMA with RAKE (ten users, uniform MIP).

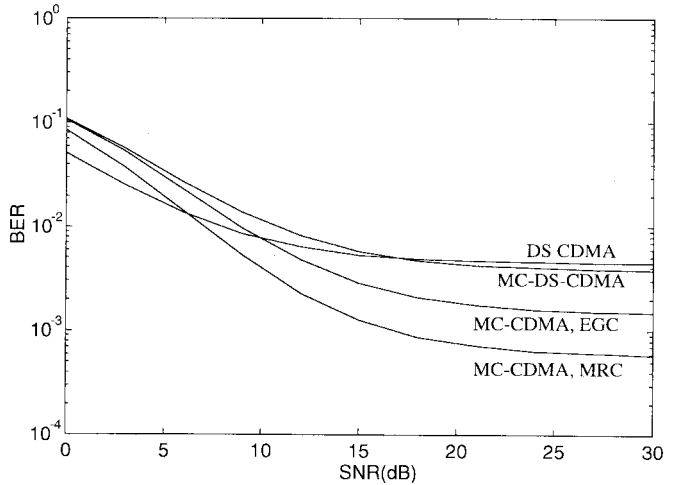

Fig. 5. Performance comparison among MC-CDMA, MC-DS-CDMA, and DS-CDMA with RAKE (ten users, uniform MIP, pulse shaping filter with roll-off factor $\alpha = 0$ is used in DS-CDMA).

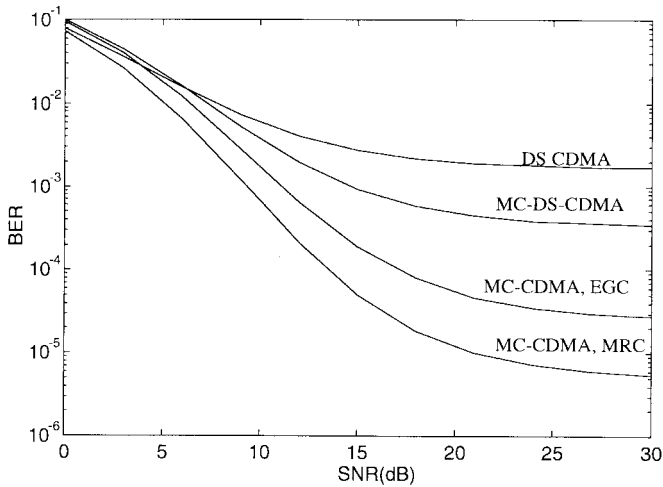

Fig. 4. Performance comparison among MC-CDMA, MC-DS-CDMA, and DS-CDMA with RAKE (10 users, exponential MIP).

performance of MC-CDMA is also evaluated under $P = 3$, but the results obtained are almost indistinguishable from those under $P = 1$. Hence, the value of P has little effect on the BER, and the choice of P is only constrained by condition (10). It is clear from the figure that MRC performs better than EGC, and the system performance is slightly better under uniform MIP due to the fact that the frequency correlation function $\rho(\cdot)$ corresponding to uniform MIP is a bit smaller than that of exponential MIP.

Next, we compare the BER performance of asynchronous reception for MC-CDMA, MC-DS-CDMA, and the conventional DS-CDMA, and the results are plotted in Figs. 3 and 4 for uniform MIP and exponential MIP, respectively. The comparison is based on the same channel condition with system parameters given in the beginning of this section, and the number of total users in the system is fixed at 10. The BER of MC-CDMA is obtained with $P = 1$ and both EGC and MRC. For DS-CDMA, a RAKE receiver with MRC is employed to take advantage of all four paths, and the BER is obtained using the analytical results of [24]. The BER of

MC-DS-CDMA is evaluated using the result of [3] where it is obtained under the assumption that only the Rayleigh envelopes of successive identical-bit carriers are correlated with correlation coefficient $\rho = 0.25$ and the number of identical-bit carriers is five with two paths per carrier, and the receiver for each carrier is a RAKE receiver with EGC, which coherently combines the signals from the two paths. Note that for MC-DS-CDMA, since the bandwidth on each carrier is larger than the coherent bandwidth and the spectra of signals on successive carriers overlaps, it is difficult to analytically evaluate the correlation coefficient of the fading envelopes of the overlapping signals [3]. Bit interleaving is often used to reduce the correlation, which brings additional advantage to the MC-DS-CDMA. However, as can be seen from the figures, MC-CDMA always performs better than MC-DS-CDMA. As compared with conventional DS-CDMA, we see conventional RAKE receiver has a small advantage when the SNR is small (<5 dB), especially in the case of uniform MIP. Otherwise, it is clear that MC-CDMA with MRC performs the best, followed by MC-CDMA with EGC, MC-DS-CDMA, and the conventional DS-CDMA. This reveals the fact that MC-CDMA is a bandwidth efficient system.

We also compare these three systems under the situation that raised cosine filter with roll-off factor $\alpha = 0$ is used in the DS-CDMA. By using raised cosine filter with roll-off factor $\alpha = 0$, the bandwidth occupied by DS-CDMA is constrained to $1/T_c$. For fair comparison, the system bandwidth of MC-DS-CDMA and MC-CDMA is also reduced to $1/T_c$ instead of $2/T_c$ as in former examples. The BER performance for uniform MIP and exponential MIP are plotted in Figs. 5 and 6, respectively. In the evaluation of the BER of band-limited DS-CDMA, the method of [23], which introduces a magnifying factor $(=3(1-\alpha/4)/2)$ to the variances of multiple access interference and multipath interference are used. As the graphs indicate, band-limited DS-CDMA with RAKE receiver performs better at small SNR. The result is more apparent in the case of uniform MIP. However, for the error floor, MC-CDMA with MRC is still the lowest, although with a smaller margin compared to

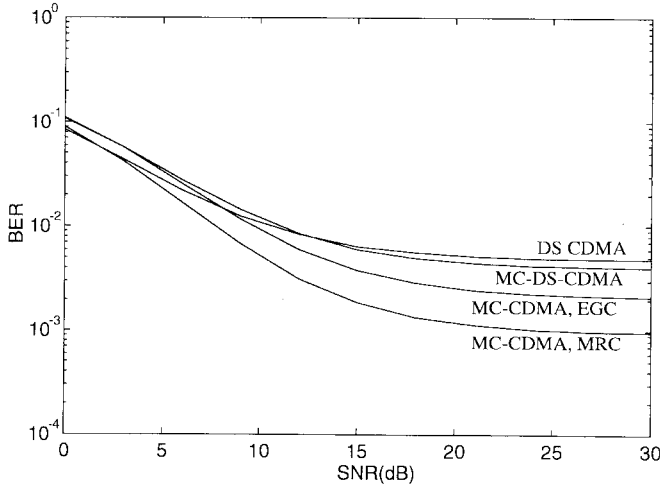

Fig. 6. Performance comparison among MC-CDMA, MC-DS-CDMA, and DS-CDMA with RAKE (ten users, exponential MIP, and pulse shaping filter with roll-off factor $\alpha = 0$ is used in DS-CDMA).

the former example. This suggests that multicarrier diversity is better than multipath diversity in terms of BER performance. The interpretation for the above observations is as follows: 1) At small SNR, where the white noise and fading effects dominate the multiple access interference (MAI) from other users, the system performance mainly depends on the diversity order achieved. For the band-limited case, MC-CDMA has less frequency diversity due to the reduction in bandwidth usage, while DS-CDMA with RAKE receiver is still assumed to be able to make full use of the path diversity and therefore has better performance at small SNR. 2) At large SNR where MAI dominates, due to the orthogonality between carriers and the narrow-band signaling on each carrier, the MAI caused by intercarrier interference is less than that caused by interpath interference. In order to achieve the same diversity, the use of multicarrier introduces less MAI than the use of multipath does. Therefore, the BER performance of multicarrier diversity is better than that of multipath diversity.

V. CONCLUSION

A method for the analysis of BER performance of an asynchronous orthogonal multicarrier CDMA system for the uplink has been presented for both EGC and MRC. Numerical result indicates that the best BER performance of such a system is achieved by using maximum ratio combining, and the system has lower error floor than the DS-CDMA as well as the MC-DS-CDMA under the same channel and bandwidth conditions.

APPENDIX

In this appendix we derive the expressions of decision variable U_p given by (17). Using (16), (17) can be expanded as

$$U_p = \int_0^{T_s} \eta(t) \sum_{l=1}^L a_{1,l}(0) \cos(\omega_l t + \phi_{1,l}(0)) \alpha_{1,l} dt + V \quad (\text{A1})$$

where the first term of the right-hand side (RHS) of (A1) is due to Gaussian noise and is denoted by η in (18). The term

V is given by

$$V = \int_0^{T_s} \left(\sum_{n=-\infty}^{+\infty} \sqrt{2S} \sum_{k=1}^K \sum_{q=1}^P \sum_{h=1}^L \beta_{k,j}(t) b_{k,q}(n) a_{k,h}(n) \cdot u_{T_s}(t - nT_s - \zeta_k) \cos(\omega_j t + \phi_{k,j}(t)) \right) \cdot \sum_{l=1}^L a_{1,l}(0) \cos(\omega_l t + \phi_{1,l}(0)) \alpha_{1,l} dt. \quad (\text{A2})$$

In the above equation, since notations p, l, i have been used for the reference data bit, notations q, h, j are substituted for subscriptions p, l, i of (16), respectively, for clarity. Separating the signal of the reference user (user 1) from the received signals, (A2) can be rewritten as

$$V = V_1 + V_2 \quad (\text{A3})$$

where V_1 is due to the reference user and is given by

$$V_1 = \int_0^{T_s} \left(\sum_{n=-\infty}^{+\infty} \sqrt{2S} \sum_{q=1}^P \sum_{h=1}^L \beta_{1,j}(t) b_{1,q}(n) a_{1,h}(n) \cdot u_{T_s}(t - nT_s) \cos(\omega_j t + \phi_{1,j}(t)) \right) \cdot \sum_{l=1}^L a_{1,l}(0) \cos(\omega_l t + \phi_{1,l}(0)) \alpha_{1,l} dt. \quad (\text{A4})$$

Due to the orthogonality between carriers, (A4) can be simplified to

$$V_1 = \sqrt{\frac{S}{2}} T_s b_{1,p}(0) \sum_{l=1}^L \beta_{1,i}(0) \alpha_{1,i}. \quad (\text{A5})$$

The desired output D_p given in (19) and (31) can be readily obtained by setting $\alpha_{1,i} = 1$ and $\alpha_{1,i} = \beta_i$ in (A5), respectively.

The term V_2 in (A3) is the interference from other users and is given by

$$V_2 = \int_0^{T_s} \left(\sum_{n=-\infty}^{+\infty} \sqrt{2S} \sum_{k=2}^K \sum_{q=1}^P \sum_{h=1}^L \beta_{k,j}(t) b_{k,q}(n) a_{k,h}(n) \cdot u_{T_s}(t - nT_s - \zeta_k) \cos(\omega_j t + \phi_{k,j}(t)) \right) \cdot \sum_{l=1}^L a_{1,l}(0) \cos(\omega_l t + \phi_{1,l}(0)) \alpha_{1,l} dt. \quad (\text{A6})$$

Changing the order of summation, (A6) can be rewritten as

$$V_2 = \sum_{l=1}^L \int_0^{T_s} \left(\sum_{n=-\infty}^{+\infty} \sqrt{2S} \sum_{k=2}^K \sum_{q=1}^P \sum_{h=1}^L \beta_{k,j}(t) b_{k,q}(n) \cdot a_{k,h}(n) u_{T_s}(t - nT_s - \zeta_k) \cos(\omega_j t + \phi_{k,j}(t)) \right) \cdot a_{1,l}(0) \cos(\omega_l t + \phi_{1,l}(0)) \alpha_{1,l} dt. \quad (\text{A7})$$

Carry out the integration in (A7), the result consists of two parts and we denote them with I_l and $J_{p,l}$, respectively. Then

(A7) can be written as

$$V_2 = \sum_{l=1}^L I_l + \sum_{l=1}^L J_{p,l} = I + J_p. \quad (A8)$$

The term I_l is from carriers of other users with frequency ω_i , and $J_{p,l}$ is from carriers of other users with frequency $\omega_j \neq \omega_i, j = 1, \dots, PL$. From (A7) it is easy to find

$$I_l = \sqrt{\frac{S}{2}} \sum_{k=2}^K \alpha_{1,i} \beta_{k,i}(0) \cos(\phi_{k,i}(0) - \phi_{1,i}(0)) \cdot [b_{k,p}(-1)a_{k,l}(-1)a_{1,l}(0)\zeta_k + b_{k,p}(0)a_{k,l}(0) \cdot a_{1,l}(0)(T_s - \zeta_k)] \quad (A9)$$

and

$$J_{p,l} = \sqrt{\frac{S}{2}} \sum_{k=2}^K \sum_{q=1}^P \sum_{\substack{h=1 \\ j \neq i}}^L \alpha_{1,i} \beta_{k,j}(0) \cdot \left\{ \int_0^{\zeta_k} b_{k,q}(-1)a_{k,h}(-1)a_{1,l}(0) \cdot \cos((\omega_i - \omega_j)t + \phi_{k,j}(0) - \phi_{1,i}(0)) dt + \int_{\zeta_k}^{T_s} b_{k,q}(0)a_{k,h}(0)a_{1,l}(0) \cdot \cos((\omega_i - \omega_j)t + \phi_{k,j}(0) - \phi_{1,i}(0)) dt \right\}. \quad (A10)$$

Substitute (A9) and (A10) into (A8) and setting $\alpha_{1,i} = 1$ and $\alpha_{1,i} = \beta$, respectively, (20) and (32) for I , (21) and (33) for J_p can be obtained.

REFERENCES

[1] D. L. Schilling, "Wireless communications going into the 21st century," *IEEE Trans. Veh. Technol.*, vol. 43, pp. 645-652, Aug. 1994.
 [2] N. Morinaga, M. Nakagawa, and R. Kohno, "New concepts and technologies for achieving highly reliable and high-capacity multimedia wireless communications systems," *IEEE Commun. Mag.*, pp. 34-40, Jan. 1997.
 [3] E. A. Sourour and M. Nakagawa, "Performance of orthogonal multicarrier CDMA in a multipath fading channel," *IEEE Trans. Commun.*, vol. 44, pp. 356-366, Mar. 1996.
 [4] ———, "Performance of orthogonal multi-carrier CDMA in nonfading and nonselective fading channels," in *Proc. IEEE 3rd Int. Symp. Spread Spectrum Techniques and Applications*, Oulu, Finland, July 4-6, 1994, pp. 203-207.
 [5] R. W. Chang, "Synthesis of band-limited orthogonal signals for multi-channel data transmission," *Bell Syst. Tech. J.*, vol. 45, pp. 1775-1796, Dec. 1966.
 [6] B. R. Saltzberg, "Performance of an efficient parallel data transmission system," *IEEE Trans. Commun. Technol.*, vol. 15, pp. 805-811, Dec. 1967.
 [7] S. B. Weinstein and P. M. Ebert, "Data transmission by frequency-division multiplexing using the discrete Fourier transform," *IEEE Trans. Commun. Technol.*, vol. 19, pp. 628-634, Oct. 1971.
 [8] J. A. C. Bingham, "Multicarrier modulation for data transmission: An idea whose time has come," *IEEE Commun. Mag.*, pp. 5-14, May 1990.
 [9] N. J. Fliege, "Orthogonal multiple carrier data transmission," *European Trans. Telecommunications and Related Technologies*, vol. 3, pp. 255-264, May/June 1992.
 [10] N. Yee, J. P. Linnartz, and G. Fettweis, "Multi-carrier CDMA in indoor wireless radio networks," *IEICE Trans. Commun.*, vol. E77-B, pp. 900-904, July 1994.
 [11] S. Kaiser and K. Fazel, "A flexible spread-spectrum multi-carrier multiple-access system for multi-media applications," in *Proc. 1997 Int. Symp. Personal, Indoor and Mobile Radio Communications*, Helsinki, Finland, Sept. 1-4, 1997, pp. 100-104.

[12] K. Fazel, S. Kaiser, and M. Schnell, "Flexible and high performance cellular mobile communications system based on orthogonal multicarrier SSMA," *Wireless Personal Commun.*, vol. 2, pp. 121-144, Nov. 1995.
 [13] Q. Chen, E. S. Sousa, and S. Pasupathy, "Performance of a coded multi-carrier DS-SSMA system in multi-path fading channels," *Wireless Personal Commun.*, vol. 2, pp. 167-183, Nov. 1995.
 [14] R. A. Stirling-Gallacher and G. J. R. Povey, "Comparison of MC-CDMA with DS-SSMA using frequency domain and time domain RAKE receivers," *Wireless Personal Commun.*, vol. 2, pp. 105-119, Nov. 1995.
 [15] R. Prasad and S. Hara, "An overview of multi-carrier CDMA," in *Proc. IEEE 4th Int. Symp. Spread Spectrum Techniques and Applications*, Mainz, Sept. 22-25, 1996, pp. 107-114.
 [16] L. Vandendorpe, "Multitone spread spectrum multiple access communications system in a multipath Rician fading channel," *IEEE Trans. Veh. Technol.*, vol. 44, pp. 327-337, May 1995.
 [17] J. G. Proakis, *Digital Communications*. New York: McGraw-Hill, 1989.
 [18] K. W. Yip and T. S. Ng, "Efficient simulation of digital transmission over WSSUS channels," *IEEE Trans. Commun.*, vol. 43, pp. 2907-2913, Dec. 1995.
 [19] ———, "Karhunen-Loève expansion of the WSSUS channel output and its application to efficient simulation," *IEEE J. Select. Areas Commun.*, vol. 15, pp. 640-646, May 1997.
 [20] M. Schwartz, W. R. Bennett, and S. Stein, *Communication Systems and Techniques*. New York: IEEE Press, 1996.
 [21] M. C. Jeruchim, P. Balaban, and K. S. Shanmugan, *Simulation of Communication Systems*. New York: Plenum, 1992.
 [22] W. H. Press, B. P. Flannery, S. A. Teukolsky, and W. T. Vetterling, *Numerical Recipes: The Art of Scientific Computing*. New York: Cambridge Univ. Press, 1986.
 [23] Y. Asano, Y. Daido, and J. M. Holtzman, "Performance evaluation of band-limited DS-SSMA communication system," in *Proc. 43rd IEEE Veh. Technol. Conf.*, 1993, pp. 464-468.
 [24] T. Eng and L. B. Milstein, "Coherent DS-SSMA performance in Nakagami multipath fading," *IEEE Trans. Commun.*, vol. 43, pp. 1134-1143, Feb./Mar./Apr. 1995.
 [25] K. S. Shanmugan and A. M. Breipohl, *Random Signals: Detection, Estimation and Data Analysis*. New York: Wiley, 1988.



Xiang Gui (S'95-M'98) was born in Jiangsu, China, in July 1969. He received the B.S. and M.S. degrees from Shanghai Jiao Tong University, China, in 1991 and 1994, respectively, and the Ph.D. degree from the University of Hong Kong in 1998, all in electrical engineering.

In 1994, he was an Assistant Lecturer in the Department of Electrical Power Engineering, Shanghai Jiao Tong University, China. Currently he is a Research Fellow, in the School of Electrical & Electronic Engineering, Nanyang Technological University, Singapore. His current research interests include spread spectrum techniques, digital signal processing, wireless communication systems and artificial intelligence.



Tony T. S. Ng (S'74-A'78-SM'90) is a graduate of HKU in 1972, received the M.Eng.Sc. and Ph.D. degrees from the University of Newcastle, Australia, in 1974 and 1977, all in electrical engineering.

He worked for BHP Steel International and The University of Wollongong, Australia, after graduation for 14 years and returned to Hong Kong in 1991, taking up the position of Professor and Chair of Electronic Engineering. His expertise is in mobile communication systems, spread spectrum techniques, CDMA and digital signal processing. He is currently VP-Region 10 of IEEE CAS Society and an Executive Committee Member and a Board Member of the IEE Informatics Divisional Board. He has published more than 170 International journal and conference papers. He is currently a Regional Editor of the *International Journal—Engineering Applications of Artificial Intelligence* (Pergamon Press).

He was awarded the Honorary Doctor of Engineering Degree by the University of Newcastle, Australia, in August 1997 for his services to higher education generally and to engineering education specifically.

He is a Fellow of the IEE, HKIE, IEAust and a Senior Member of IEEE.