

Bionic chair system with pressure sensing and adjustment*

Grantham K.H. Pang, *Senior Member, IEEE*, Bingjing Wang, and Enid Kwong

Abstract— Many people are spending longer time sitting, and hence more attention is being drawn on the pressure distribution. Sitting pressure distribution is important because having high pressure concentrated on one area might lead to muscular soreness and discomfort. This problem is especially acute for people having problem of pressure ulcers, for high pressure can cause more severe pain. This paper aims to develop a chair that enables pressure sensing at multiple locations in real-time and therefore the sitting pressure distribution is known. The Arduino Mega board has been used to process and display the sensing data. Pressure distributions on four different surfaces were tested, and the effectiveness of cushions were verified. Ten robotic extenders are implemented at the base of the chair with an aim to adjusting the pressure distribution, and the effectiveness of this mechatronics feature was tested. The finding is that the retraction function is effective to decrease pressure. This paper provides a direction for constructing bionic chair system with sitting pressure sensing and adjustment. It might contribute to achieving flexible and customized pressure distribution according to different requirements.

I. INTRODUCTION

Nowadays, many people spend much time sitting. As long-time sitting might cause muscular soreness, it is increasingly important to improve the comfort level that a chair can provide. Jun et al. [1] and Makhsous [2] discussed on the importance of having a comfortable chair and examined how pressure distribution is an important factor to the comfort level. Objective measures on sitting comfort is discussed in [3, 4]. Tan et al. [5] and Daian et al. [6] developed a chair with pressure sensing capability. Their aim was to classify the sitting posture of the person sitting on it. Another concern on the pressure distribution of a chair is highly related to healthcare [7]. In nursing homes and medical facilities, some seniors and elders are suffering from the problem of pressure ulcers [8, 9]. They are problems on an area of skin that breaks down, which occur when things keep pressing or rubbing against the skin. It is usually a localized injury to the skin and its underlying tissue over a bony prominence. The elderly are at high risk of developing pressure ulcers due to poor physical health situations and confinement to chair or bed. Therefore, active mechanism that can alleviate the pressure on a specific region of the chair associated to the pressure ulcer would be beneficial to these people. Existing measurement devices include

Xsensor X3 medical seat & back system [10] and Tekscan [11]. However, most devices rely on PC connection for displaying and evaluating the pressure distribution. This paper makes use of the Arduino board as the processor. This would remove the need of a PC and the complete system is able to work independently. This work has developed a pressure sensing mat that can function on Arduino [12] and its associated LCD screen. A display device, Adafruit 2.8" TFT LCD, has been used to display the pressure distribution obtained in real-time. The effectiveness of using cushions on chairs has been verified by the pressure mapping function of the developed device.

In addition to monitoring the pressure distribution, we would like to further adjust it. Hence, another objective of this work is to adjust the pressure distribution. This work has used robotics extenders to adjust the shape of the surface of the mat and hence attempted to adjust the pressure distribution. Experiments have been conducted to verify the modification of the pressure distribution of a mat to enable customizable setting. The rest of this paper is structured as follows. Section 2 explains the methodologies involved. Section 3 is on system evaluation, and Section 4 gives the experimental results. Section 5 presents the conclusion, which includes the limitations and difficulties.

II. METHODOLOGY

A. Pressure Sensing

The principle behind the pressure sensing is the property of force sensitive resistor. The resistance of the force sensitive resistor changes according to the force applied on sensor. Figure 1 shows the picture of the force sensor used [13]. The force sensitive resistors in this project are FSR @ 406. A sensor array consisting of 16 sensors are used. The sensors are made of robust polymer thick film. Each of them could sense the range of force from about 0.2N to 20N. When a user sits on them, a sensor would translate the exerted force to a decrease in resistance.

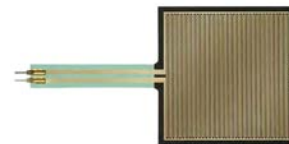

Figure 1. A photo of the thin-sheet sensor

B. Hardware Design

The block diagram of the bionic chair system is shown in Figure 2. The Arduino microcomputer is the main controller for all other devices. The sensor information of

*Research supported by The University of Hong Kong, IARL. Prof. G. Pang is with the Dept. of Elec. & Electronic Engg., The University of Hong Kong, Pokfulam, Hong Kong. (phone: 852-2857-8492; fax: 852-2559-8738; e-mail: gpang@eee.hku.hk). Ms. Bingjing Wang is with the Dept. of Elec. & Electronic Engg., The University of Hong Kong. Prof. Enid Kwong is with the School of Nursing, Putian University, Fuzhou, P. R. China.

pressure level on each force sensitive resistor (components of the pressure sensing mat) is inputted to the Arduino Mega board in the form of voltage value. The pressure sensing mat is constructed with 16 sensors (Fig. 3). The Arduino Mega board would process the data and send to the Adafruit TFT LCD [14] for display. When the user clicks on a button on the Adafruit TFT LCD, the coordinates will be passed back to the Arduino Mega board for subsequent processing.

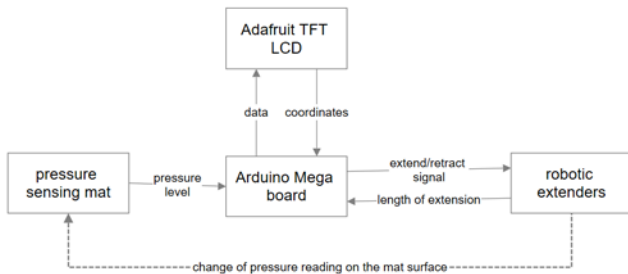

Figure 2. Block diagram of the system

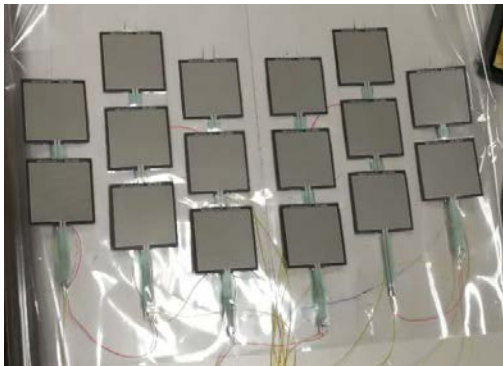

Figure 3. Pressure sensing mat

In the mechatronic chair system, ten robotic extenders (Figure 4) are located below the cushion. There is a plastic board supporting the cushion for sitting, and there are drilled holes on the board. The top tips of the robotic extender can pass through the holes and push at the bottom of the cushion. This is shown in Figure 5. As the robotic extenders are located below the mat, their extension or retraction would influence the surface shape of the mat, hence change the pressure reading on the mat surface.



Figure 4. Robotic extenders



Figure 5. Bionic chair

Figure 6 shows the connection to the construction of one robotic extender. An 24-volt input voltage is used to drive the robotic extenders, and solid state relay (SSR) is used to function as switches in this circuit. Four solid state relays were soldered and connected by wires to facilitate the control of one robotic extender.

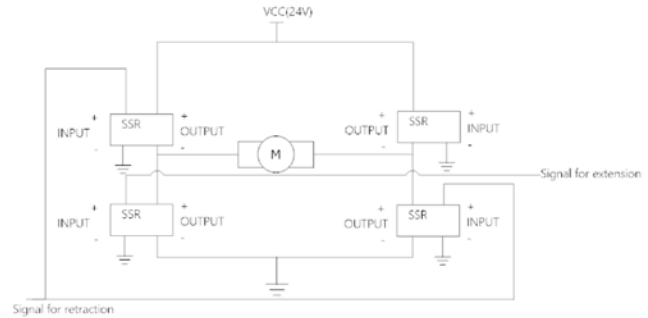

Figure 6. Connection to the robotic extender

III. SYSTEM EVALUATION

A. Pressure Sensing Mat

In this work, the pressure sensing mat is used to monitor the pressure distribution and to verify the effectiveness of pressure distributing cushion. The pressure sensing mat is also used to monitor the change in pressure distribution when the shape of cushion surface is changed by the robotic extenders. Hence, experiments have been carried out to test the pressure sensing mat on these functions.

The pressure sensing mat is tested to see if the sixteen force sensitive resistors can work simultaneously with satisfactory sensitivity and response speed. The implementation is shown in Figures 12 or 13. Forces were applied to the force sensitive resistors to check if the pressure displayed on the LCD screen were displayed properly.

Measurements are conducted on four kinds of sitting surfaces on the chair. The four surfaces are:

- plastic without cushion on it,
- plastic covered by several layers of soft fabric materials,
- cotton-padded cushion, and
- a pressure-distributing cushion.

Figure 7 shows the cushions that are used in this project.



Figure 7. Sitting materials for the evaluation

The purpose is to check if the pressure distributions are different. To get the pressure distribution, the pressure sensing mat is located above the surface to be measured. The participant (around 57 kg) would sit on the pressure sensing mat. Figure 8 shows the setup for evaluation.



Figure 8. Setup for the evaluation

To test the effectiveness of cushions for different postures, participant used five postures in the experiment. The five postures are: sit normally, lean to left, lean to right, lean forward and lean backward. The TFT touch screen would display the pressure distribution for each posture.

B. Robotic extender

It is possible to implement the length of extension by controlling the time of the extension using the Arduino Mega board. The relationship between the length of extension and on/off time of extension have been verified by multiple experiments. The software program has calculated the time interval and the switched on or off the extender by controlling the corresponding pins of the Arduino board. The length of extension is plotted against time of extension. The results of experiments are shown below. Figures 9 and 10 show the extension against time when the time interval was 0.2 and 0.5 second respectively. It shows that the gradient of extension is quite stable and linear. Figure 11 shows a comparison (in cm) between the actual extension and the desired extension (blue).

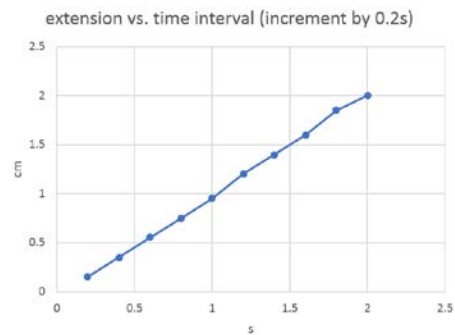

Figure 9. Extension versus time interval (increment by 0.2s)

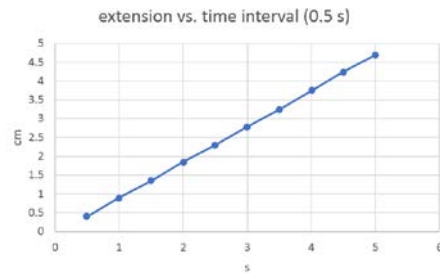

Figure 10. Extension versus time interval (increment by 0.5s)

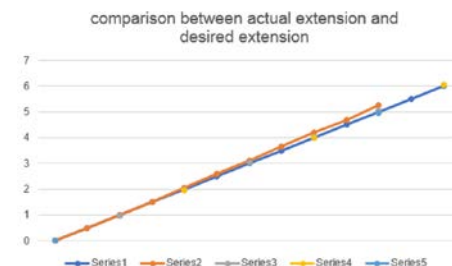

Figure 11. Comparison between actual and desired length

IV. EXPERIMENTAL RESULTS

A. Pressure Sensing Mat

The pressure sensing mat has been tested to be effective. The larger the force applied on the force sensitive resistors, the larger the voltage reading from the analog pins and these are sent to the Arduino board and displayed on the LCD screen. When force applied on several force sensitive resistors simultaneously, the readings for the corresponding analog pins increased, and no significant delay is found. Hence, it can be concluded that the force sensitive resistors can work reliably and the pressure sensing mat is functioning as expected.

The display on the screen can be shown in two modes. The following figures show the display when the person is sitting normally on the plastic surface. Figure 12 shows the pressure on the sixteen locations using squares. The size/area of the squares indicates the level of the pressure readings. The number of levels is ten and the corresponding integer values are shown in the number mode of Figure 13.

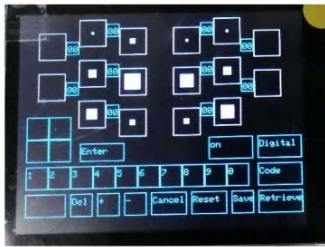

Figure 12: square mode
(plastic, normal posture)



Figure 13: number mode
(plastic, normal posture)

Next, we show in Figs. 14 & 15 the LCD screen when the plastic sitting surface is covered by some soft fabric, and a person sits normally.

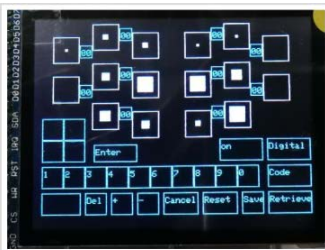

Figure 14: square mode
(soft fabric, normal posture)



Figure 15: number mode
(soft fabric, normal posture)

With the cotton-padded cushion, it can be seen (Figs. 16 & 17) that the pressure distribution is more evenly than the soft fabric surface.



Figure 16: square mode
(cotton cushion, normal)



Figure 17: number mode
(cotton cushion, normal)

The pressure distributing cushion can be seen (Figs. 18 & 19) to provide the best pressure distribution among all the four sitting surfaces.

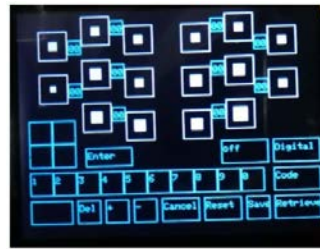

Figure 18: square mode
(pressure-distributing, normal)



Figure 19: number mode
(pressure-distributing, normal)

B. Different postures

In order to further investigate the pressure distribution, similar experiments are conducted to test the pressure distribution when the participant leans leftward, rightward, backward and forward.

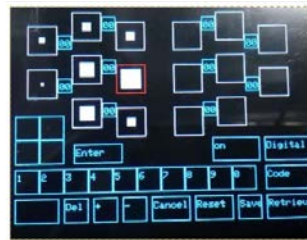

Figure 20. Pressure distribution on plastic surface, leaning left

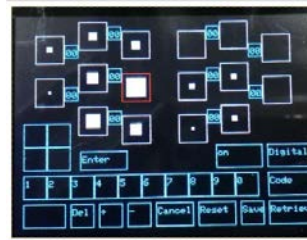
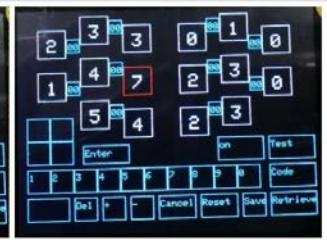

Figure 21. Pressure distribution on soft fabric, leaning left



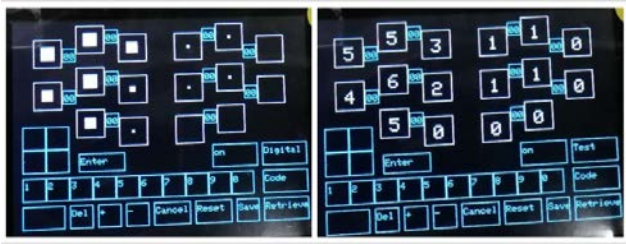

Figure 22. Cotton cushion, leaning left

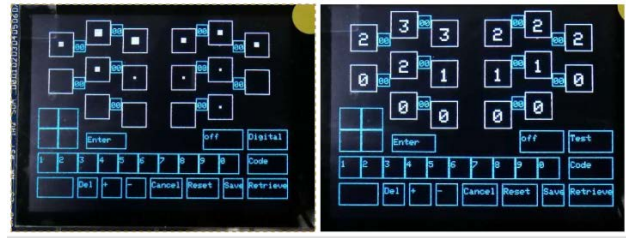

Figure 27. Pressure-distributing cushion, leaning forward

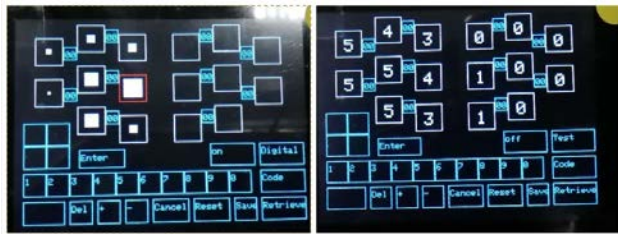

Figure 23. Pressure-distributing cushion, leaning left

Figures 20 to 23 show the pressure distribution when sitting on four different surfaces, and leaning to the left. Figures 24 to 27 show the pressure distribution when sitting on four different surfaces, and leaning forward.

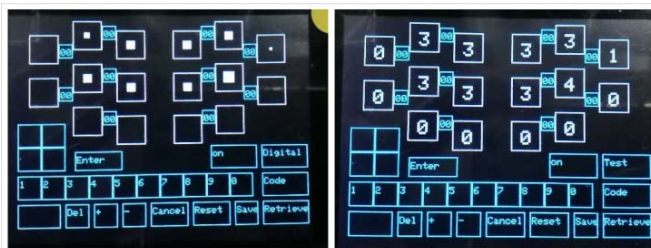

Figure 24. Pressure distribution on plastic surface, leaning forward

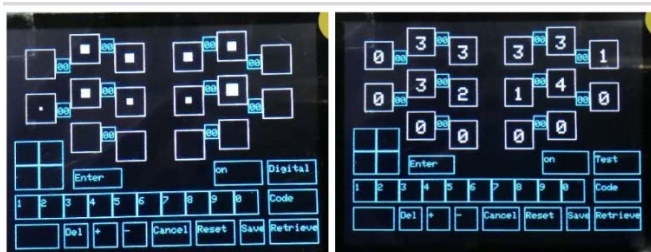

Figure 25. Pressure distribution on soft fabric, leaning forward

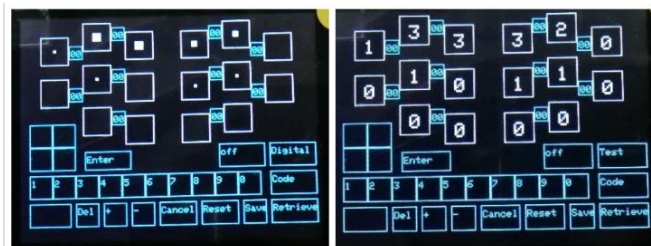

Figure 26. Cotton cushion, leaning forward

The above results all show that the pressure-distributing is the best in reducing the surface pressure of the chair. The pressure patterns are as expected. Due to space limitations, results of leaning to the right and leaning backward are not shown.

C. Effect of robotic extenders on pressure distribution by retraction

Preliminary results have shown that the pressure distribution of the sitting surface would generally increase slightly when the extenders extend from underneath the chair and push from the bottom. Suppose the aim is to decrease the pressure on the left. It is not effective to extending the extenders in other sections. The overall objective of the work is to adjust the pressure on the sitting surface so that the pressure can be reduced.

Further work has shown that with the extenders already in position, retraction of some pieces can bring about a reduction of pressure in a desired region of the surface. Figure 28 shows a pressure distribution profile (with detailed sensor reading) with a person sitting on the pressure-distributing cushion in a normal posture. All extenders were extenders to 30mm.

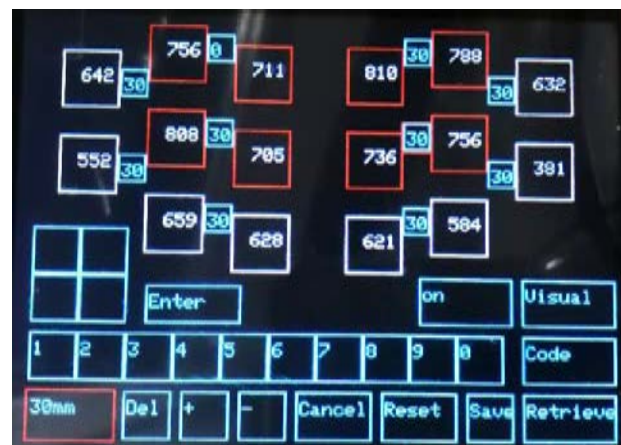

Figure 28. Pressure distribution surface

Figure 29 shows the pressure distribution when one upper left extenders is retracted. Comparing figure 28 and 29, decrease in pressure around the retracted extender could be observed (as shown by the reading within **yellow** in figure 29). Figure 30 shows the reading when one more extender retracted. The readings within the **yellow circle** shows an obvious decrease in pressure around the retracted extender.

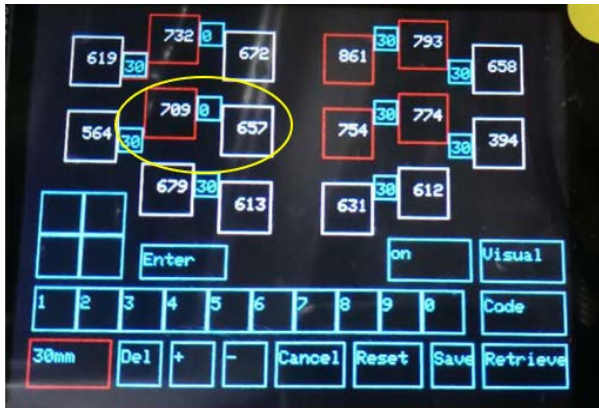

Figure 29 Pressure distribution surface (extender retracted)

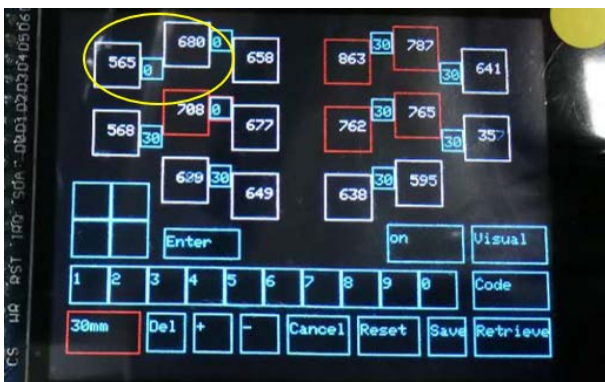

Figure 30 Pressure distribution surface(2 extenders retracted)

V. CONCLUSIONS

In this paper, a pressure sensing mat to monitor the pressure distribution is implemented, and the performance has been verified to be satisfactory. One contribution of the successful implementation that the investigation of sitting pressure distribution does not rely on personal or notebook computer. The pressure distributions on four different sitting surfaces have been studied. This investigation verifies the effectiveness of the cotton-padded cushion and the pressure distributing cushion on improving/even out pressure distribution.

On the robotics extender, the relationship between extension and time intervals has been studied to get precise control on the length of extension by controlling the time of extension. From the experimental result, it is found that extension can cause increased pressure and it is hard to decrease pressure of a specific region significantly. However, the retraction function can effectively lead to decreased pressure. This is from the observation that the pressure level around the retracted extenders has decreased.

The main limitation in the development of the pressure sensing mat is that the number of sensors is limited. As the number of Analog pins on Arduino Mega boards restricts the

number of force sensitive resistors that can be used in this project, only a very limited area can be covered. Though the performance is satisfactory, there is low tolerance of displacement. A user needs to sit on the designed position. Displacement greatly affects the performance. In the future, this problem might be solved by adding one more Arduino Mega board.

Based on this work, further research could be carried out to adjust the chair surface pressure using the robotics extenders/retractors. This could lead to a high level of comfort for the user. For the elderly suffering from pressure ulcers, the pressure adjustment function on a specified region of the chair can alleviate the problem of pressure ulcers.

REFERENCES

- [1] Y. D. Jun, E. Cho, S. H. Park. "Comfort evaluation of a coccyx seating mat based on body pressure measurements," International Information Institute (Tokyo). Information, vol. 20, pp. 3657-3666, May. 2017.
- [2] M. Makhssous, F. Lin, D. Hanawalt, S.L. Kruger, A. LaMantia. "The effect of chair designs on sitting pressure distribution and tissue perfusion," Human factors, vol. 54 pp.1066-1074.Dec. 2012.
- [3] M.P. De Looze, L.F.M. Kuijt-Evers, J. Van Dieën, "Sitting comfort and discomfort and the relationships with objective measures", Ergonomics, 01 August 2003, Vol.46(10), p.985-997.
- [4] D. Cohen, "An objective measure of seat comfort," J. Aviation, Space Environmental Medicine, vol. 69, pp. 410-414, 1998.
- [5] H.Z. Tan, L. A. Slivovsky, A. Pentland, "A sensing chair using pressure distribution sensors", IEEE/ASME Transactions on Mechatronics, September 2001, Vol.6(3), pp.261-268.
- [6] I, Daian, A. van Ruiten, A. Visser, S. Zubic, "Sensitive chair: a force sensing chair with multimodal real-time feedback via agent", Proceedings of the 14th European conference on cognitive ergonomics, 28 August 2007, pp.163-166.
- [7] T. Ergic, Z. Ivandic, D. Kozak. "The Significance of Contact Pressure Distribution on The Soft Tissue by Men sitting", International Design Conference - Design 2002. Dubrovnik. Croatia. May 2002.
- [8] E. Kwong, M. Hung, K. Woo, "Improvement of pressure ulcer prevention care in private for-profit residential care homes: An action research study", BMC Geriatrics, 16: 192, 2016.
- [9] E. Kwong, A. Lau, R. Lee, R. Kwan, "A pressure ulcer prevention programme specially designed for nursing homes: does it work? ", Journal Clinical Nursing, 20(19-20), 2777-2786, 2011.
- [10] "XSENSOR X3 Medical Seat & Back System," 2012.[Online] Available: <http://www.xsensor.com/> [Accessed: Feb 27, 2018]
- [11] "Tekscan: Pressure Mapping, Force Measurement & Tactile Sensors. [Online] Available:<http://www.tekscan.com/>[Accessed: Feb. 28, 2019]
- [12] Arduino open-source electronic prototyping platform, <https://www.arduino.cc/>.
- [13] "FSR 406 Data Sheet - Trossen Robotics," Oct. 26, 2012. [Online] Available: <https://www.trossenrobotics.com/productdocs/2010-10-26-datasheet-fsr406-layout2.pdf> [Accessed: Feb. 27, 2018]
- [14] "Adafruit TFT Touchscreen Libraries zipped file,"[Online] Available <http://moodle.hku.hk/mod/resource/view.php?id=949576> [Accessed: Sept. 10, 2017]