

A life prediction scheme for electrolytic capacitors in power converters without current sensor

Pang H. M.

Department of Electrical and Electronic Engineering
The University of Hong Kong
Hong Kong SAR, China

Pong M. H. Bryan, Senior Member IEEE

Department of Electrical and Electronic Engineering
The University of Hong Kong
Hong Kong SAR, China

Abstract—Predicting the expected life of switching power supply is essential since unexpected failure of the subsystem can produce enormous loss. Electrolytic capacitor is the weakest among various power components in a power converter. Monitoring the Equivalent Series Resistance (ESR) variation of the electrolytic capacitor, achieving by voltage and current ripple, can estimate the converter life. Currently, Hall Effect sensor or others are current sensing options but all of them add series impedance to the capacitor and deteriorate capacitor voltage waveform. A sensor-less current waveform prediction method is proposed. Popular current mode control with the switch current signal is used. Repetitive sampling on the switch current allows capacitors current waveforms prediction without any current sensor at capacitor nodes. Together with the voltage waveform acquired, the ESR value can be calculated.

I. INTRODUCTION

Power converter is an essential subsystem in various electronic equipments. Failures of power converters can lead to imminent or stoppage of the whole system. Early and accurate prediction of faults would allow preventive maintenance to be performed, reducing the costs of outage-time and repairs [7]. A better utilization of the converter, achieving by knowing the life of the device, favors green environment as well.

Currently, most power supplies only have their life estimation done in the design stage but this is not sufficient [1, 2]. Electrolytic capacitor is often the weakest component so it represents the converter life. Fig. 1 shows the failure distribution of different components in a static converter [13, 14]. Electrolytic capacitor accounts for largest portion of failures of most power converters. However, the useful life of electrolytic capacitor is strongly affected by the operating conditions [3-9]. There are numerous reasons but mainly the dry-out of electrolyte leads to evident short lifespan of electrolytic capacitor. In order to estimate power converter life accurately it is essential to monitor the operating conditions of the electrolytic capacitor and make appropriate life-span compensation.

Many researchers use various methods to predict electrolytic life [3-9]. High reliability, high power and cost insensitive applications like Uninterruptable Power Supply and DC Bus Capacitor Bank favor monitoring of the capacitor pressure and power devices. A. Riz et al. implemented inner gas pressure measurement approach with an industrial-level equipment setup [3]. M. L. Gasperi suggested a compromised model for ESR estimation from inner vapor pressure that no pressure sensing was required [4]. V. A. Sankaran et al. examined the life model by Gasperi. The experiment showed the model over-predicted the life of capacitor, suggesting the vapor pressure data alone is far from enough [5]. S. K. Maddula presented a capacitor model from Arrhenius' rule of thumb and used it in the dc bus of regenerative IM drives but accurate estimation of the core temperature was critical but difficult as self-heating effect is included [6]. E. C. Aeloiza suggested a real time ESR deterioration approach. ESR calculation is based on the assumption that under steady state power loss only comes from ESR and thus ESR is power loss produced by RMS current [7]. Direct monitoring approach is more accurate but current sensor introduces Equivalent Series Inductance (ESL) that totally changes the voltage waveform of the capacitor, as shown by fig. 2. Y. M. Chen et al. proposed a processor-free online failure prediction method for choke

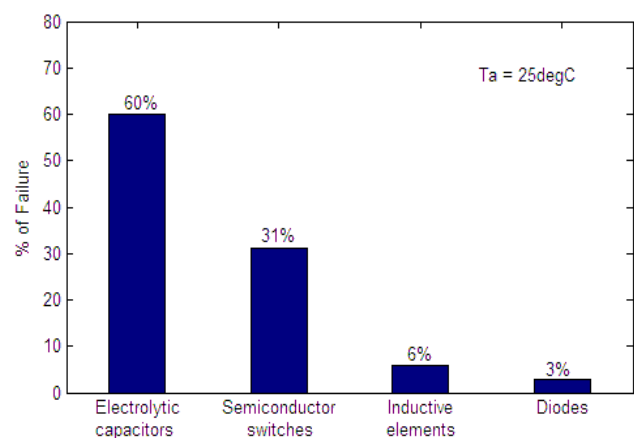

Figure 1. Distribution of failure of power components

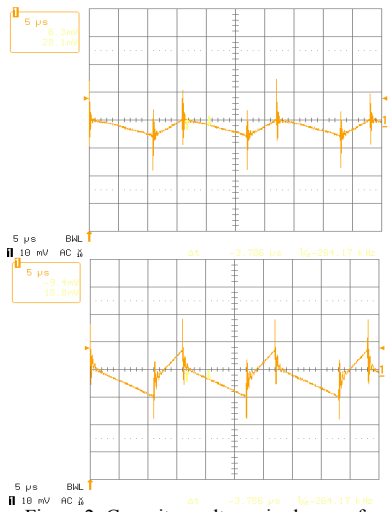

Figure 2. Capacitor voltage ripple waveform without (Upper) and with (Lower) Hall Effect current sensor

capacitor [8]. Voltage ripple variation could be detected analogically but voltage ripple change due to load variation was not considered. Hao Ma et al. proposed ESR identification system by capturing inductor current and capacitor voltage. This cannot totally eliminate impact of current sensor on the waveforms. Industrial PC was required for complicated calculation as well [9].

This paper proposes a new method to predict electrolytic capacitor life in a power converter. ESR deterioration provides direct and accurate estimation of capacitor life [7, 8]. Capacitor current information is essential for ESR monitoring but it is not desirable to put in any current sensor. Therefore, this paper aims at introducing capacitor current prediction incorporated into voltage ripple measurement to determine the state of the capacitor. Repetitive sampling on switch current, which is readily available in current mode control, allows low-speed waveform acquisition. Capacitor current can then be obtained accurately from the switch current without deteriorating the capacitor voltage waveform. Capacitor voltage can also be captured by repetitive sampling with few modifications on the Sample-and-hold circuit (S/H). With the current and voltage waveforms, ESR is equal to ratio of capacitor voltage ripple to inductor current ripple. The assumption is that ESL is negligible comparing with ESR. This is valid when the capacitor leads are cut to be short and no hall sensor is installed [8]. Fig. 3 shows the experimental captured voltage and current ripple of input capacitor, which closely follow the characteristic by (1).

$$V_{ac} = ESR \times I_{L,ac} \quad (1)$$

The dry-out of electrolyte is the evident for short lifespan of electrolytic capacitor. The liquid electrolyte has rather conspicuous temperature characteristics and so does the thermal stress have a decisive effect on the capacitor's life expectancy [5, 10-17]. The heat dissipation generated by the ripple current on ESR is an important factor affecting the useful life. An increase in ambient temperature or in internal temperature rise caused by ripple current accelerates

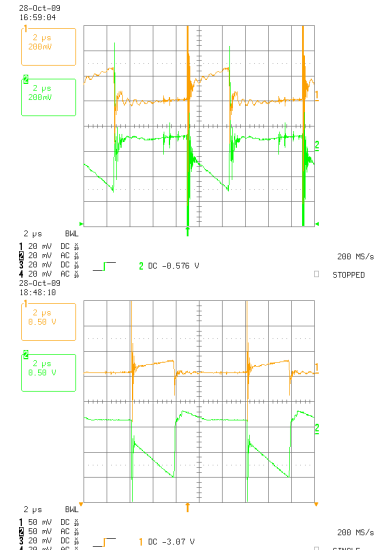

Figure 3. Capacitor voltage ripple waveform (Upper) and current ripple waveform (Lower).

evaporation of the electrolyte [5, 15-17]. By monitoring temperature and ripple current, and with the appropriate model, the life estimation of capacitor can be easily done and so can the power converter life be predicted.

Low cost Analog-to-digital conversion (ADC) and microprocessor can achieve the acquisition and calculation, enabling mass production. Fig. 4 shows the proposed system setup on forward converter. It is well known that forward input capacitor life is critical and ESR monitoring is therefore applied to the input capacitor.

II. CURRENT CAPTURING TECHNIQUE

Sensor-less approach to predict the capacitors' information is more preferable as any sensor attached to electrolytic capacitor will distort the voltage waveform across it. Applying sensor also means heavy cost barrier to mass production. Typical current mode control scheme detect the switch current peak to control the switching duty. The current through the switching semiconductor is already available. If more information can be obtained from this current waveform, waveforms of input and output capacitor can be predicted.

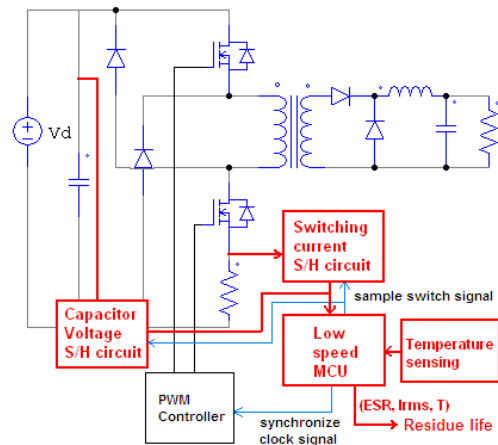

Figure 4. Proposed ESR detection system.

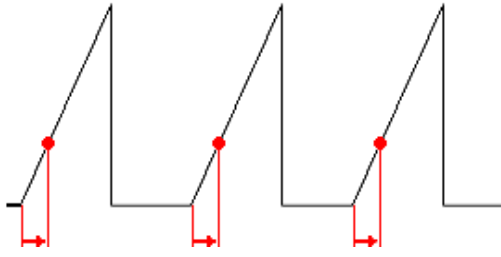

Figure 5. Repetively sampling a point for a number of cycles before A/D conversion is completed

An essential point is the acquisition of the switching current into the digital microcontroller platform. Direct high-speed ADC of switch current to digital platform is achievable but it is neither economical nor essential. Sample-and-hold circuit and repetitive sampling technique can achieve the same purpose with a slow ADC. This is making use of the repetitive nature of the switching current waveform. The current waveform is sampled at a point for a number of cycles, and waits for the A/D conversion to complete before moving onto the next point. Repeating the sampling throughout the switching cycle, the current waveform can be acquired with low-cost ADC and S/H.

Acquiring the switch current waveform, ESR and the ripple currents RMS² of the input (I_{rms2}) and output capacitors (I_{orms2}) can be calculated. This can be applied to all the basic power converter topologies, namely the buck, boost and buck-boost converters and their isolation counterparts Forward and Flyback converters. Equations for Forward and Flyback capacitors' ripple current calculations in CCM and DCM are listed. Fig. 6 and fig. 7 shows the ideal capacitor current waveforms and experimental current waveforms respectively.

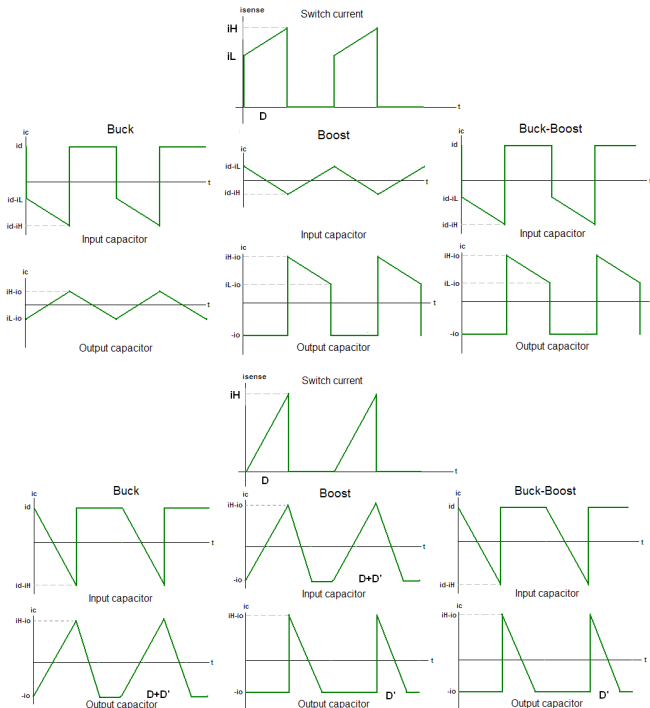

Figure 6. Switch current and capacitors current for CCM and DCM cases

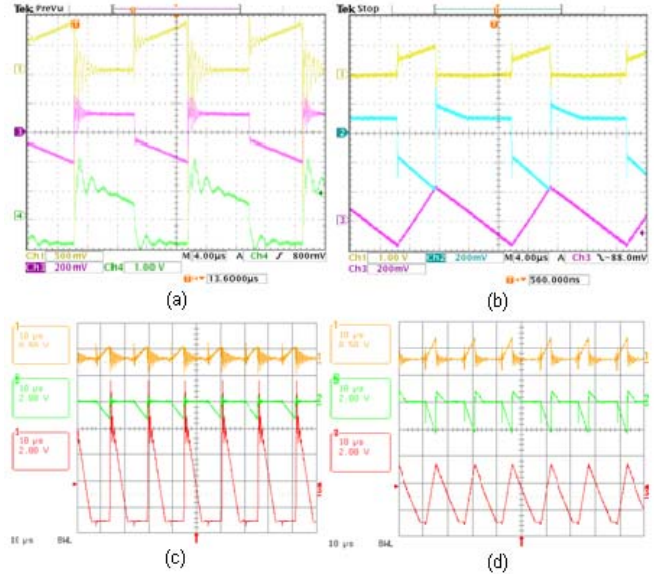

Figure 7. Experimental waveforms for a)CCM Flyback, b)CCM Forward, c)DCM Flyback, d)DCM Forward (upper: switch current; middle: input capacitor current; lower: output capacitor current)

a) CCM Forward converter:

$$I_{d rms}^2 = \frac{1}{12} [(i_L^2 + i_H^2)(-3D^2 + 4D) + i_L i_H (-6D^2 + 4D) + i_m^2 D_r] \quad (2)$$

$$I_{o rms}^2 = \frac{1}{12} (n(i_H - i_m) - n i_L)^2 \quad (3)$$

where i_L : lower current peak; i_H : higher peak; D : switch duty; i_m : transformer magnetizing current; D_r : reset duty; n : transformer turn ratio.

Note that the magnetizing current should be much smaller than that of switch load current for equation (2) to be accurate. Otherwise higher order equation is required.

b) CCM Flyback converter:

$$I_{d rms}^2 = \frac{1}{12} [(i_L^2 + i_H^2)(-3D^2 + 4D) + i_L i_H (-6D^2 + 4D)] \quad (4)$$

$$I_{o rms}^2 = \frac{1}{12} [(i_{Lsec}^2 + i_{Hsec}^2)(-3D^2 + 2D + 1) + i_{Lsec} i_{Hsec} (-6D^2 + 8D - 2)] \quad (5)$$

where $i_{Lsec} = n \cdot i_L$; $i_{Hsec} = n \cdot i_H$.

c) DCM Forward converter:

$$I_{d rms}^2 = \frac{1}{12} i_H^2 (-3D^2 + 4D) \quad (6)$$

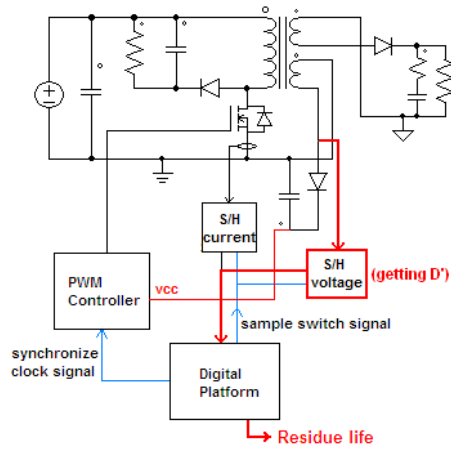

Figure 8. Current capturing system for DCM Flyback

$$I_{o_{rms}}^2 = \frac{1}{12} n (i_H - i_m)^2 [-3(D+D')^2 + 4(D+D')] \quad (7)$$

d) DCM Flyback converter:

$$I_{d_{rms}}^2 = \frac{1}{12} i_H^2 (-3D^2 + 4D) \quad (8)$$

$$I_{o_{rms}}^2 = \frac{1}{12} i_{Hsec}^2 (-3D'^2 + 4D') \quad (9)$$

Flyback converter does not require a filter choke. This is an advantage of the topology from device view point. It brings problem when predicting the output capacitor current since the secondary current fall-time and D' then highly depend on output leakage inductance. This gives rise to large calculation error. One additional voltage sense at auxiliary IC supply winding is implemented to obtain the unknown directly. Fig. 8 shows the system configuration with additional voltage feedback. It does not require any extra winding or special-designed transformer but a simple S/H circuit to sense D' effectively.

III. EXPERIMENTAL RESULTS

A. Capacitor current prediction

The performance of the S/H circuit is verified in fig. 9. Small discrepancy is found between actual waveform (dotted line) and sampled one (solid line). This is mainly caused by the switching noise and under-sampling at current peak. Some minor effects include sample switch gate discharging current and capacitor leakage. Both analog and digital filter design can help reducing noise. Freescale microcontroller MC68HC908MR32 was written to perform the bit-shifting and current ripple calculation at a clock frequency of 4 MHz. Higher sampling frequency can improve the accuracy of peak value detection.

Two 120W CCM converters (Forward and Flyback) and low power DCM converter were built to verify the accuracy of the current calculation system. The parameters extracted from

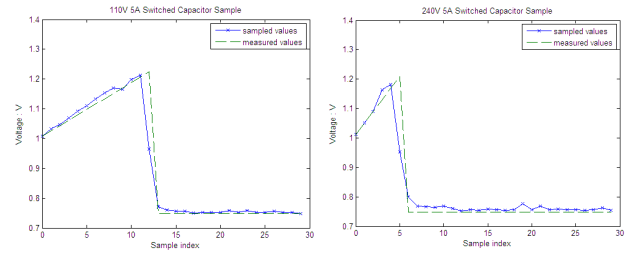

Figure 9. Comparison between switch current waveforms captured by repetitive sampling (solid line) and measured waveforms from scope (dotted line).

the current waveforms and the calculated current ripple square RMS values at different input voltages and loads, obtained from the microprocessor, are shown in tables in the appendix with their corresponding readings from the measurement equipment by current probes. The Error rows give the percentage errors between the calculated output and input capacitor current ripple square RMS values (I_{orms} and I_{drms}) and the measured values.

Calculated capacitor current values for CCM Forward converter have errors range from 1.36% to 7.25%. Sources of errors mainly come from calculation and data acquisition. Acquisition error mainly involves sampling error mentioned previously, magnetizing current peak and reset duty estimation error (in Forward case) and errors from high frequency oscillation by parasitic elements. Calculation error includes truncation error in calculating process and over-simplification of equations. Even so, errors are less than 10%, which is well acceptable. Likewise, the errors of calculated capacitor currents are low for other operation modes and topology. Some gives error as low as 0.45%, which is comparable to measurement errors. These verify the accuracy of the capacitor current prediction method.

B. Online ESR monitoring

The proposed online ESR monitoring method can be applied to different switch mode power converters. A conventional 2-FET Forward converter, as shown in fig. 4, was built to test the performance of the method. Specifications of the Forward converter are listed as follow.

Input voltage $V_{in} = 360$ V

Output voltage $V_{out} = 24$ V

Maximum output current $I_{out} = 8$ A

Switching frequency $f_s = 100$ kHz

Input capacitor $C_{out} = 180 \mu\text{F}$, 450 V, 105 C,

Rubycon MXG series

Measured ESR = 306m Ω (25 $^\circ\text{C}$, 100 kHz)

Transformer $L_m = 3.3$ mH

Transformer turn ratio $n = 5$

Output inductor $L_{out} = 60 \mu\text{H}$

Fig. 10 shows the experimental captured voltage and current ripple of input capacitor at full load (8A) condition. The measured results are listed in the table. Note that the

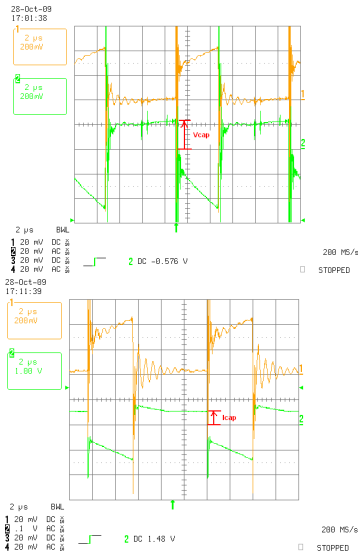

Figure 10. Forward input capacitor voltage ripple waveform (Upper) and current ripple waveform (Lower)

reading for captured ripple voltage (V_{cap}) and ripple current (I_{cap}) were taken when either voltage probe or current probe was inserted solely. Both voltage and current probes were removed while reading the ESR value. This is essential as these probes will interrupt the sampling system, by means of inserting impedance or providing leakage path. The calculated results' errors range from 2% to 8%, which is well within the acceptable range. Experimental results show that the proposed online monitoring can be applied to the switching-mode power converter successfully.

TABLE I. RESULTS FOR ESR MONITORING

	Half load: 4A		Full load: 8A	
	Captured	Measured	Captured	Measured
IL	0.517	0.510	1.244	1.230
IH	1.177	1.170	1.928	1.920
D	0.388	0.381	0.388	0.381
I_{cap}	0.282	0.277	0.563	0.565
V_{cap}	0.099	0.095	0.189	0.196
Irms2	0.186	0.194	0.613	0.625
Irms Error	4.12%		1.92%	
ESR	0.329	0.306	0.330	0.306
ESR Error	7.52%		7.84%	

IV. RESIDUE LIFE REPORTING

With the calculated real time capacitor current ripple and ESR, capacitor self-heating loss can be monitored. And the remaining capacitor life can be worked out with an appropriate life model. Several electrolytic capacitor manufacturers provide their life equations [10-11]. It is generally agreed that the effect of temperature on capacitor life is dictated by the Law of Arrhenius [5, 9-12]. The temperature-dependent life model is established to the familiar "life doubles in every 10°C" rule in electrolytic capacitor industry. Table below shows one of the proposed life models [4, 9, 11]. Note that the accuracy of life prediction heavily depends on the life equation itself. But with the real-time monitoring, the deviation due to changing operational

conditions can be eliminated and the prediction accuracy can be improved accordingly. This is also what this paper aims for.

TABLE II. RESULTS FOR ESR MONITORING

	Equations
Arrhenius law	$\frac{L_p}{L_r} \approx 2^{\frac{T_r - T_p}{10}}$
Capacitor core temperature	$T_{core} = T_A + \alpha \Delta T$
Temperature rise by self heating	$\Delta T = \frac{I^2 \times ESR}{\beta \times S}$
Thermal resistance	$\beta = 2.3 \times 10^{-3} \times S^{-0.2}$
Capacitor surface area	$S = 2\pi(r^2 + rh)$

Adding additional or build-in temperature sensing equipment for ambient temperature, the microprocessor can work out the core temperature of the capacitor and thus the life degradation by the model. The program flowchart is shown in fig. 11. Programmed shifting subroutine generates sampling gate signals for sampling circuit and performs ADC for captured samples (1). Temperature is also captured next (2). When all data inputs are finished, the program analyzes the stored sample data to obtain useful parameters like duty and peak values. Current RMS values are then calculated from programmed equations (3). ESR is also calculated (4). With all necessary data is ready, capacitor life degradation in the predefined period is then calculated from the model (5) and is used to renew the residue life of the capacitor (6).

How to obtain the life degradation? The capacitor life under certain working condition is repeatedly calculated by the microcontroller. The obtained values are then used to modify the remaining life of the capacitor as shown in fig. 12. The calculated life is the reciprocal of slope. This can be easily proved by assuming the capacitor is working under the

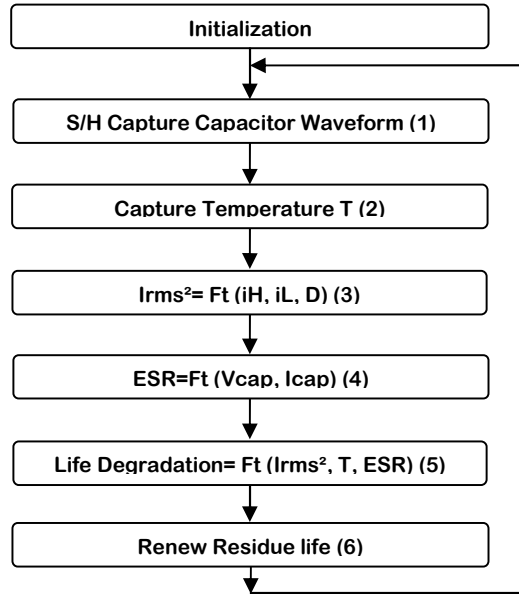

Figure 11. Main program flowchart

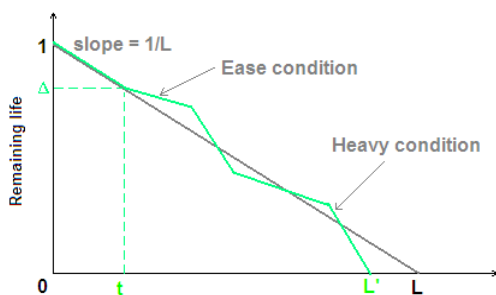

Figure 12. Graph of remaining life against time

rated condition throughout its life, as shown by grey straight line. Then the total operating time is L as remaining life portion drops from 1 to 0 and the slope is $m = 1/L$. Time t is the predefined data renew period which means the new capacitor life result is available every t second. The heavier the working condition over the period gives steeper slope and the life degradation is faster. With known time t and slope m , the new remaining life portion Δ is projected on Y-axis. Storing up the value Δ , the remaining life of the capacitor can be known. This value can be sent out as PWM duty percentage for computer monitoring.

V. CONCLUSIONS

A new method to predict power converter life through estimation of electrolytic capacitor ESR and ripple current is presented. This method employs no current sensor to measure capacitor current. The popular current mode control current signal is taken. The input and output capacitor currents are calculated. Together with capacitor voltage ripple monitoring the capacitor ESR can be estimated. Power loss on ripple current can be worked out and the life can accurately be estimated. This method is geared towards low cost mass produced power converter. The platform employs a simple microprocessor and waveform digitization technique. Implementation to two power converters verifies the current prediction accuracy. A completed prototype that can tell the ESR is built. One life model employing core temperature estimation derived from ESR deterioration and operating conditions is shown with detailed instructions for implementation.

APPENDIX

TABLE III. CURRENT CAPTURE RESULT FOR CCM FORWARD

I:120V O:5A	iL	iH	D	I _{orms}	I _{drms}
Calculated	0.649	0.201	0.310	1.250	1.130
Measured	0.648	0.208	0.310	1.300	1.190
Error				3.85%	5.04%
I:120V O:10A	iL	iH	D	I _{orms}	I _{drms}
Calculated	1.020	0.558	0.341	1.350	3.740
Measured	1.000	0.552	0.341	1.370	3.690
Error				1.46%	1.36%
I:240V O:5A	iL	iH	D	I _{orms}	I _{drms}
Calculated	0.643	0.160	0.154	2.270	0.609
Measured	0.648	0.162	0.155	2.130	0.619
Error				6.57%	1.62%
I:240V O:10A	iL	iH	D	I _{orms}	I _{drms}
Calculated	1.040	0.504	0.170	2.890	2.220

Measured	1.040	0.504	0.165	2.820	2.070
Error				2.48%	7.25%

TABLE IV. CURRENT CAPTURE RESULT FOR DCM FORWARD

I:120V O:2A	iH	D	Dd	I _{orms}	I _{drms}
Calculated	0.434	0.280	0.640	1.813	0.511
Measured	0.430	0.281	0.627	1.866	0.494
Error				2.84%	3.44%
I:240V O:2A	iH	D	Dd	I _{orms}	I _{drms}
Calculated	0.438	0.143	0.711	2.404	0.246
Measured	0.430	0.138	0.700	2.344	0.256
Error				2.56%	3.91%

TABLE V. CURRENT CAPTURE RESULT FOR CCM FLYBACK

I:120V O:5A	iL	iH	D	I _{orms}	I _{drms}
Calculated	0.132	0.493	0.448	25.7	0.505
Measured	0.134	0.49	0.449	25.3	0.530
Error				1.58%	4.72%
I:120V O:10A	iL	iH	D	I _{orms}	I _{drms}
Calculated	0.452	0.809	0.465	89.1	1.810
Measured	0.451	0.797	0.470	89.7	1.850
Error				0.67%	2.16%
I:240V O:5A	iL	iH	D	I _{orms}	I _{drms}
Calculated	0.030	0.484	0.279	21.9	0.314
Measured	0.040	0.494	0.284	22.0	0.345
Error				0.45%	8.99%
I:240V O:10A	iL	iH	D	I _{orms}	I _{drms}
Calculated	0.271	0.727	0.296	54.5	0.988
Measured	0.269	0.730	0.294	54.8	1.020
Error				0.55%	3.14%

TABLE VI. CURRENT CAPTURE RESULT FOR DCM FLYBACK

I:120V O:2A	iH	D	Dd	I _{orms}	I _{drms}
Calculated	0.318	0.371	0.472	7.306	0.157
Measured	0.310	0.374	0.475	7.150	0.159
Error				2.18%	1.26%
I:240V O:2A	iH	D	Dd	I _{orms}	I _{drms}
Calculated	0.315	0.205	0.472	7.131	0.099
Measured	0.310	0.213	0.472	7.258	0.095
Error				1.75%	4.21%

REFERENCES

- [1] Xijin Tian, "Design-for-reliability and implementation on power converters", Reliability and Maintainability Symposium 2005, 24-27 Jan. 2005, pp. 89-95
- [2] A. D. Dominguez-Garcia and P.T. Krein, "Integrating reliability into the design of fault-tolerant power electronics systems", Power Electronics Specialists Conference, PESC 2008, 15-19 June 2008, pp. 2665-2671
- [3] A. Riz, D. Fodor, O. Klug and Z. Karaffy, "Inner gas pressure measurement based life-span estimation of electrolytic capacitors", Power Electronics and Motion Control Conference, 2008. EPE-PEMC 2008. 13th, 1-3 Sept. 2008, pp. 2096-2101
- [4] M. L. Gasperi, "Life prediction modeling of bus capacitors in AC variable-frequency drives", IEEE Transactions on Industry Applications, Volume 41, Issue 6, Nov.-Dec. 2005, pp.1430-1435
- [5] V. A. Sankaran, F. L. Rees and C. S. Avant, "Electrolytic capacitor life testing and prediction", Industry Applications Conference, 1997. Thirty-Second IAS Annual Meeting, IAS '97., Volume 2, 5-9 Oct. 1997, pp.1058-1065
- [6] S. K. Maddula and J. C. Balda, "Lifetime of Electrolytic Capacitors in Regenerative Induction Motor Drives", Power Electronics Specialists Conference, 2005. PESC '05. IEEE 36th, 16-16 June 2005 pp.153-159

- [7] E. C. Aeloiza, J. H. Kim, P. Ruminot and P. N. Enjeti, "A Real Time Method to Estimate Electrolytic Capacitor Condition in PWM Adjustable Speed Drives and Uninterruptible Power Supplies", Power Electronics Specialists Conference, 2005. PESC '05. IEEE 36th, 16 June 2005, pp.2867-2872
- [8] Yaow-Ming Chen, Hsu-Chin Wu, Ming-Wei Chou and Kung-Yen Lee, "Online Failure Prediction of the Electrolytic Capacitor for LC Filter of Switching-Mode Power Converters", IEEE Transactions on Industrial Electronics, Volume 55, Issue 1, Jan. 2008, pp.400-406
- [9] Hao Ma and Linguo Wang, "Fault diagnosis and failure prediction of aluminum electrolytic capacitors in power electronic converters", IEEE Industrial Electronics Society 31st Annual Conference, IECON 2005, 6-6 Nov. 2005, pp. 6 pp.-
- [10] CDE Cornell Dubilier, "Application Guide Aluminum Electrolytic Capacitors" www.cornell-dubilier.com
- [11] Rubycon Corporation, "Technical Notes for Electrolytic Capacitor" www.rubycon.com
- [12] Maniktala, Sanjaya., "Switching power supply design & optimization", McGraw-Hill Professional, 2005, pp. 5-7, 324, 361-369
- [13] P. Venet, F. Perisse, M. H. El-Husseini and G. Rojat, "Realization of a smart electrolytic capacitor circuit", IEEE Industry Applications Magazine, Volume 8, Issue 1, pp. 16-20, Jan/Feb 2002
- [14] Reliability Prediction of Electronic Equipment, Military Handbook 217 F, 1995.
- [15] K. Harada, A. Katsuki and M. Fujiwara, "Use of ESR for deterioration diagnosis of electrolytic capacitor", IEEE Transactions on Power Electronics, Volume 8, Issue 4, pp. 355-361, Oct 1993
- [16] Afroz M. Imam, "Condition monitoring of electrolytic capacitors for power electronics applications", PhD. Dissertation, Georgia Institute of Technology, 2007
- [17] M. L. Gasperi, "A method for predicting the expected life of bus capacitors", Industry Applications Conference, 1997. Thirty-Second IAS Annual Meeting, IAS '97, Volume 2, 5-9 Oct 1997, pp. 1042-1047